

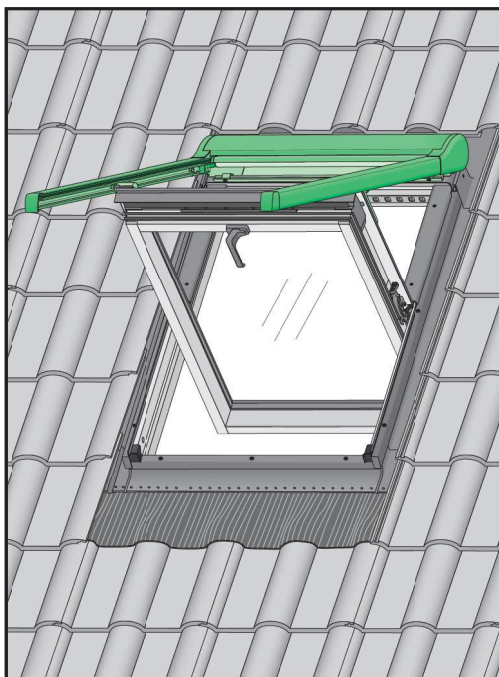

AMZ Z-Wave

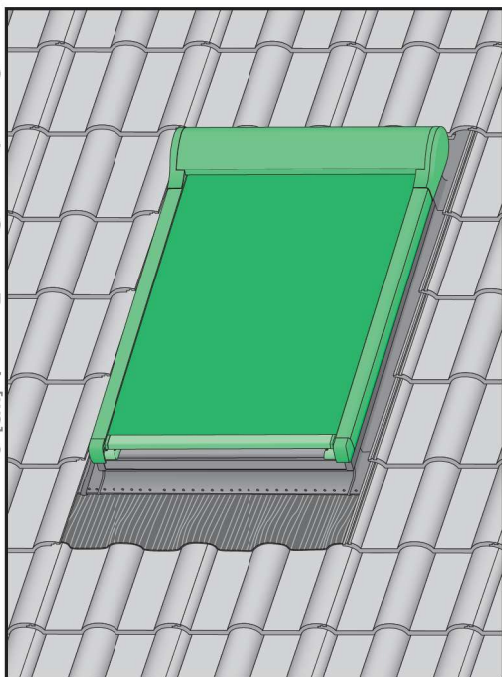

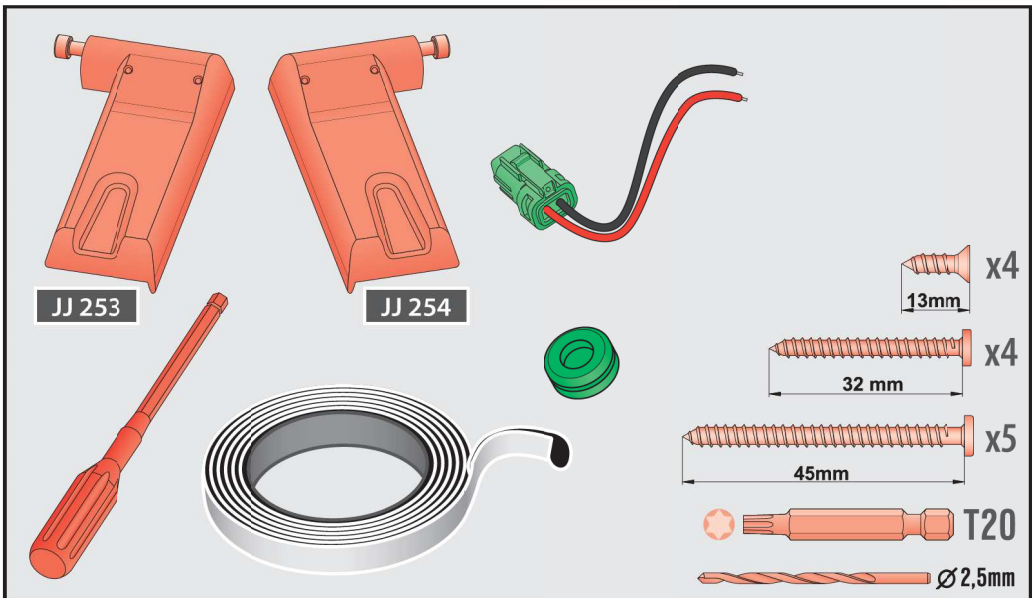
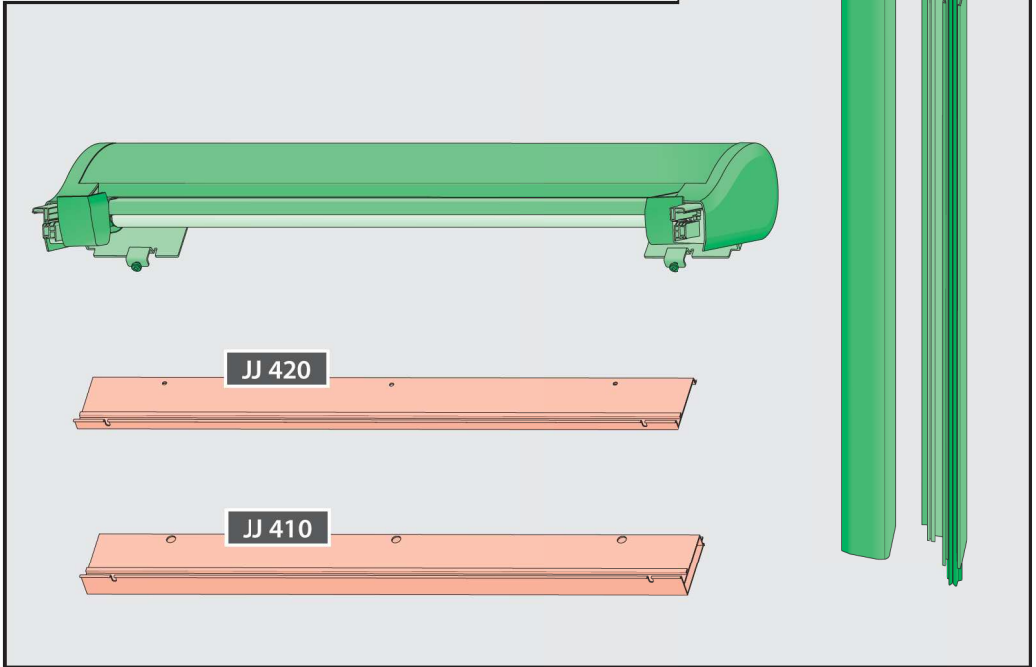
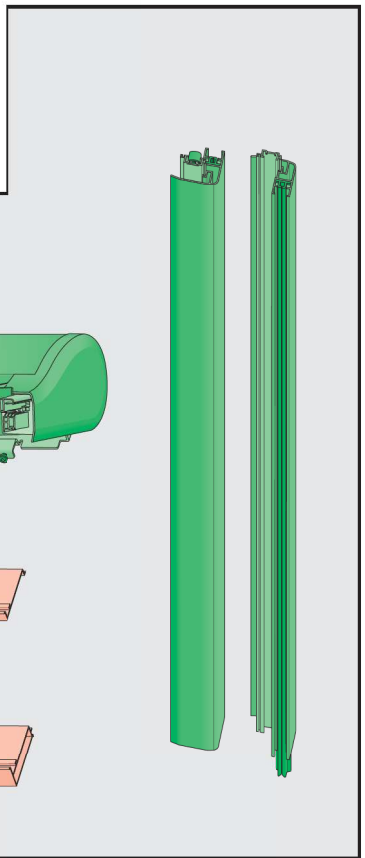

1

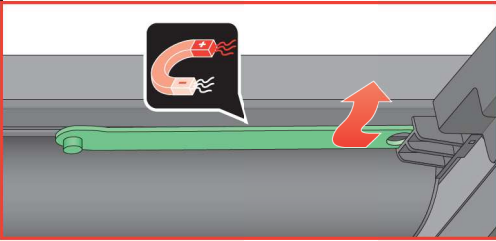
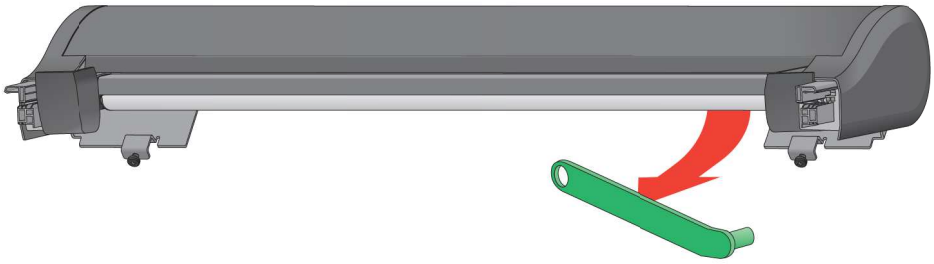

2

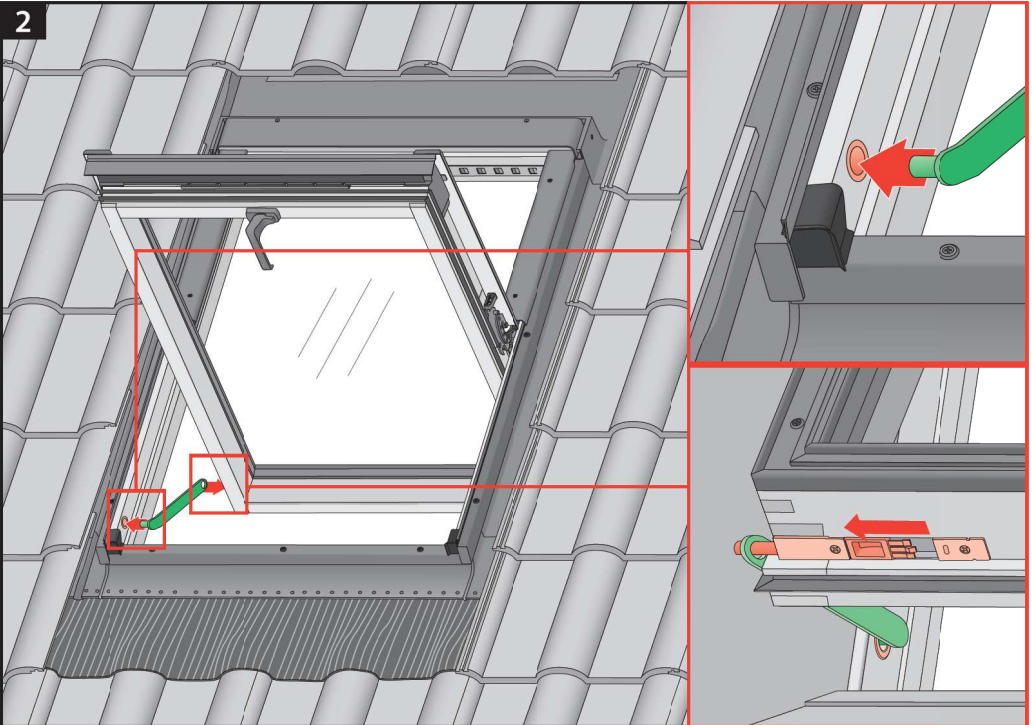

3

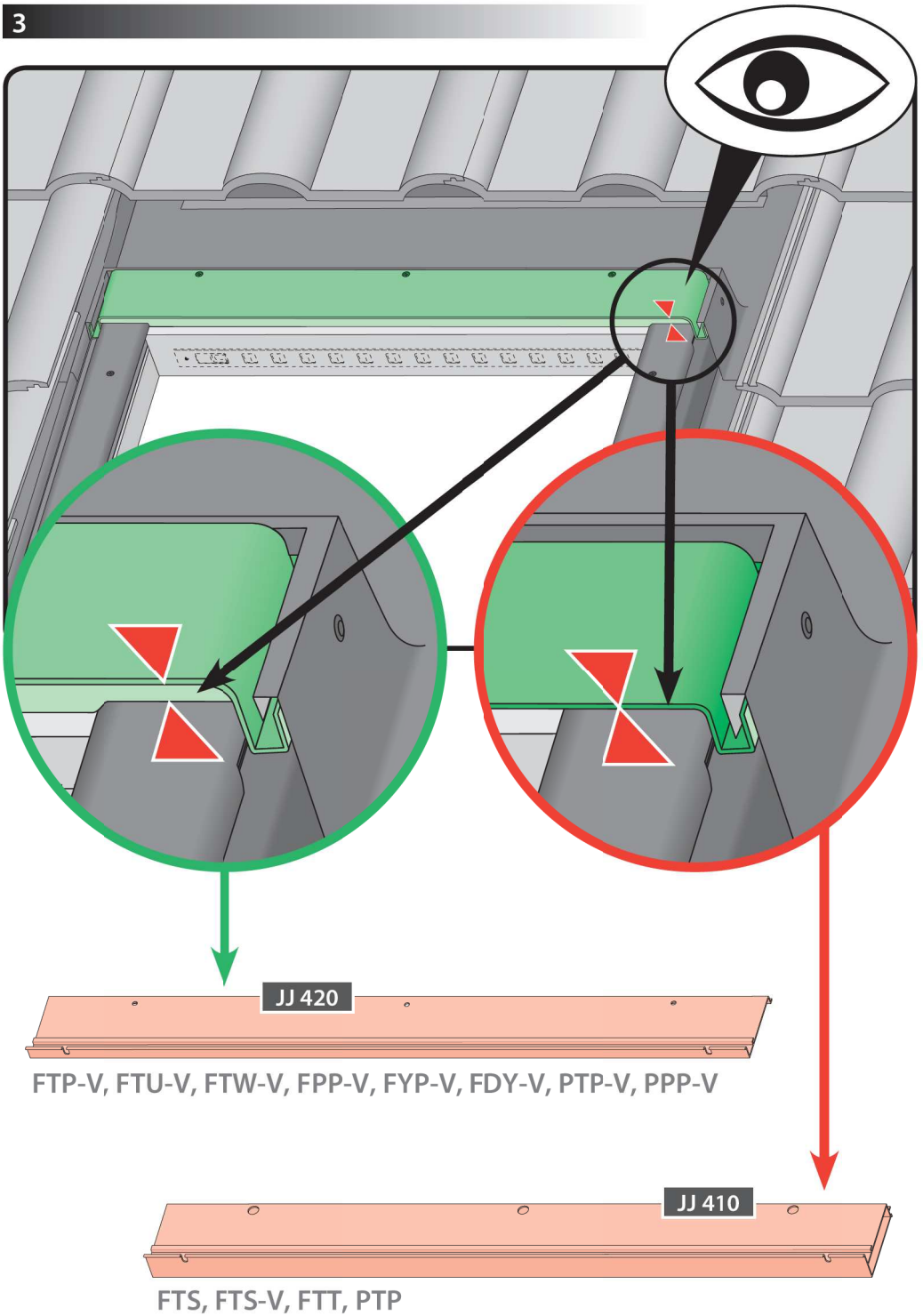

3a

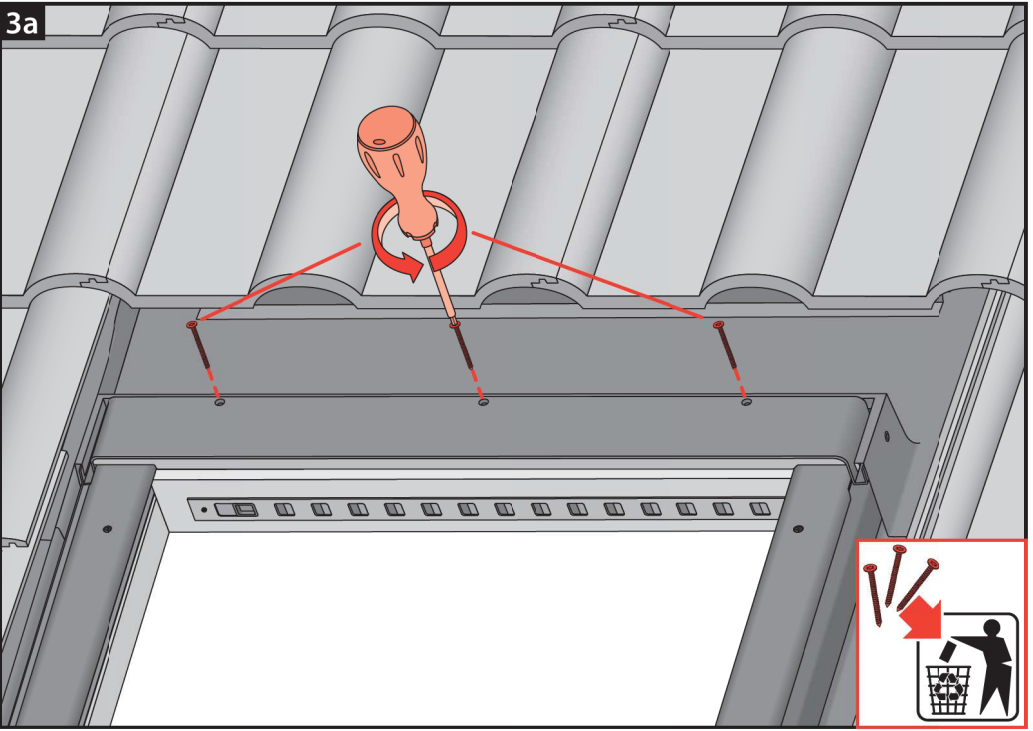

3b

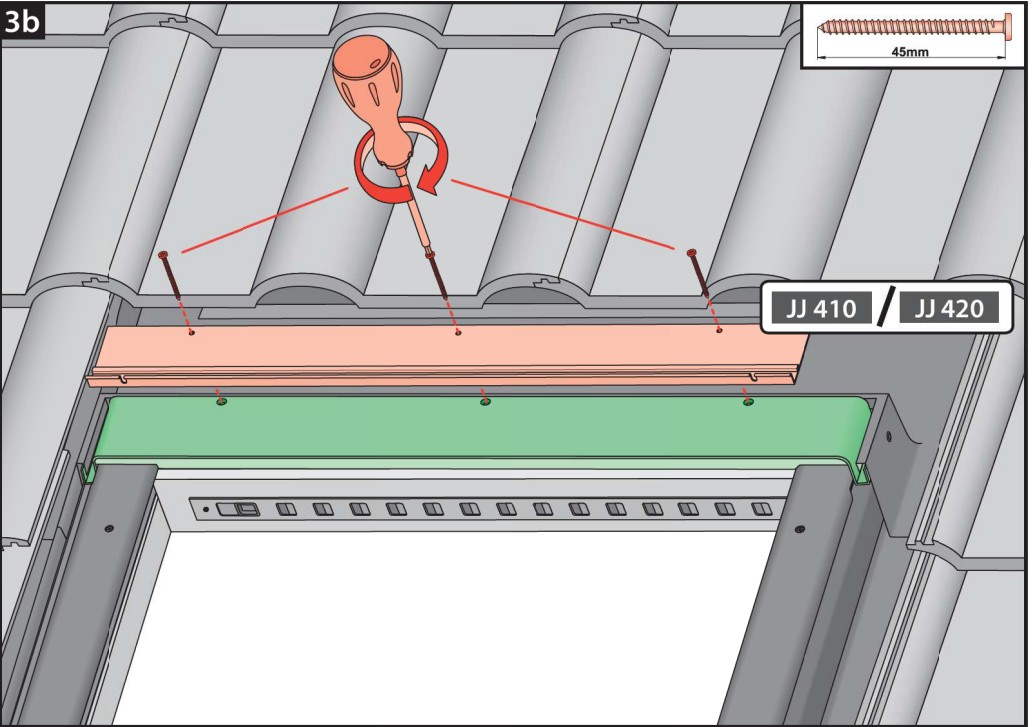

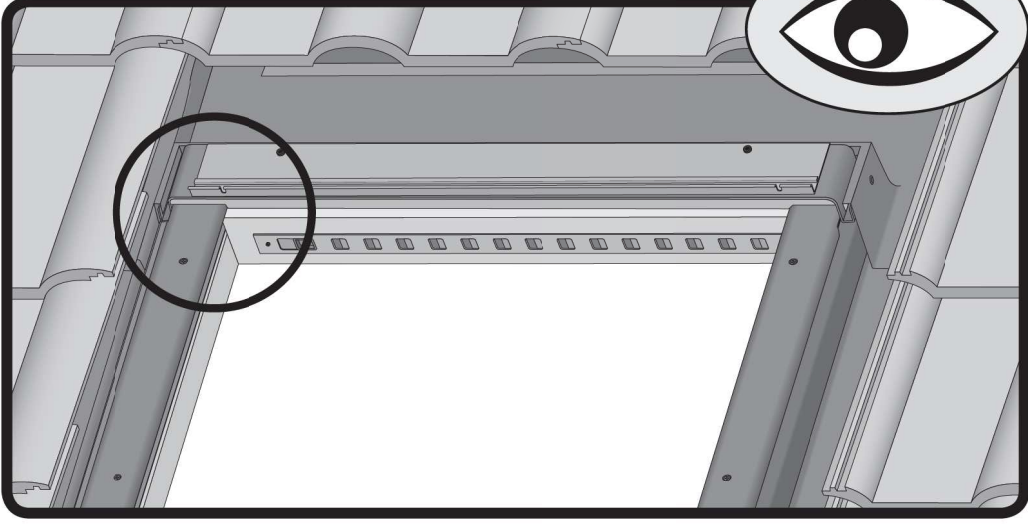
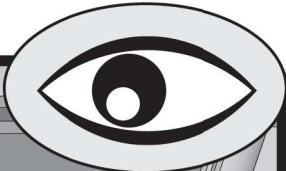

type A

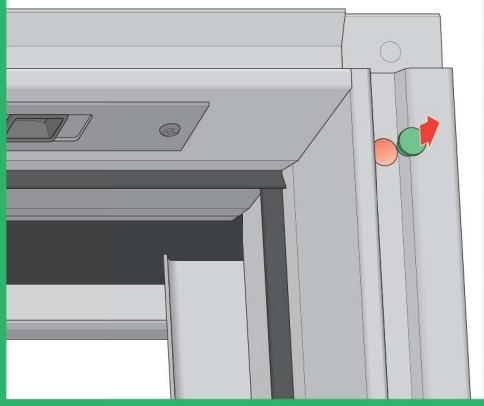

FTS, FTS-V, FTP, FTP-V, FYP, FYP-V
 FTT, FDY-V, FPP preSelect 2
 PTP, PTP-V, PYP, PYP-V

type B

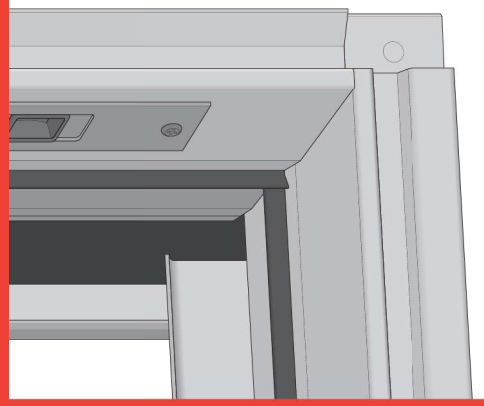

FTS, FTS-V, FTP, FTP-V, FYP, FYP-V
 FTT, FDY-V, FPP preSelect
 PTP, PTP-V, PYP, PYP-V



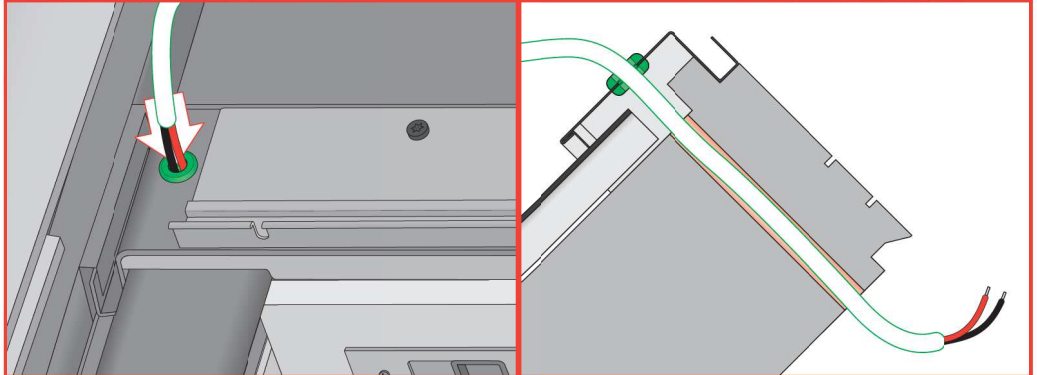
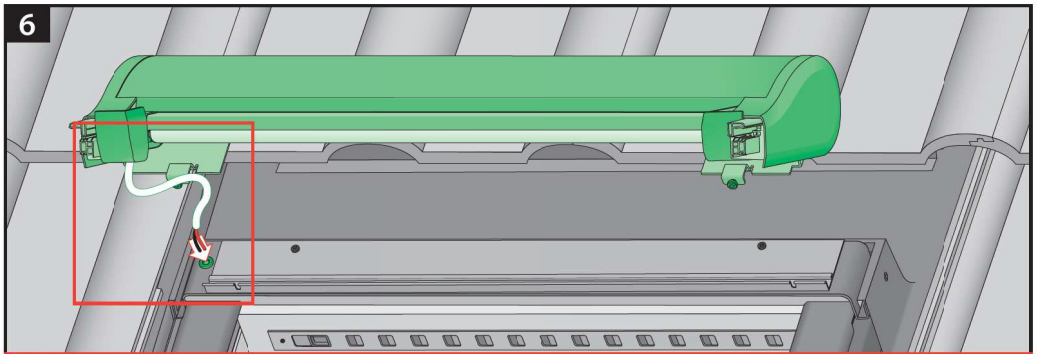
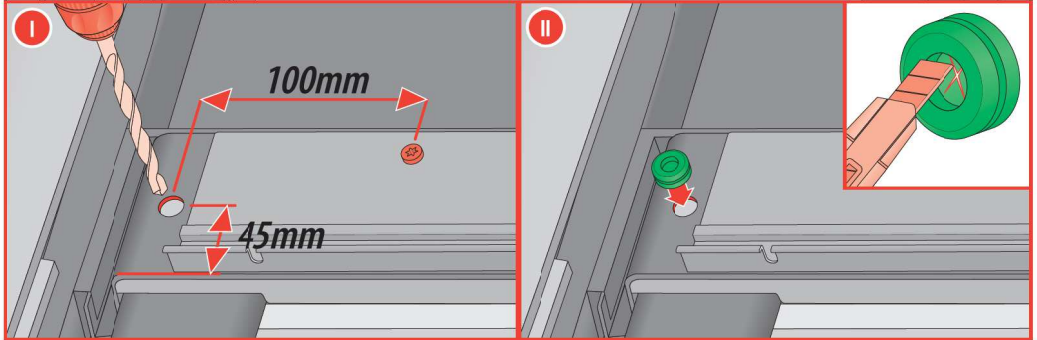
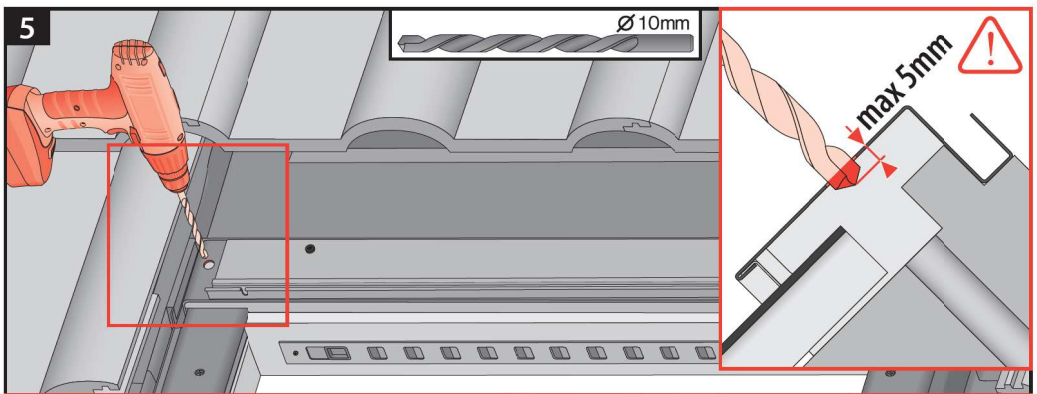

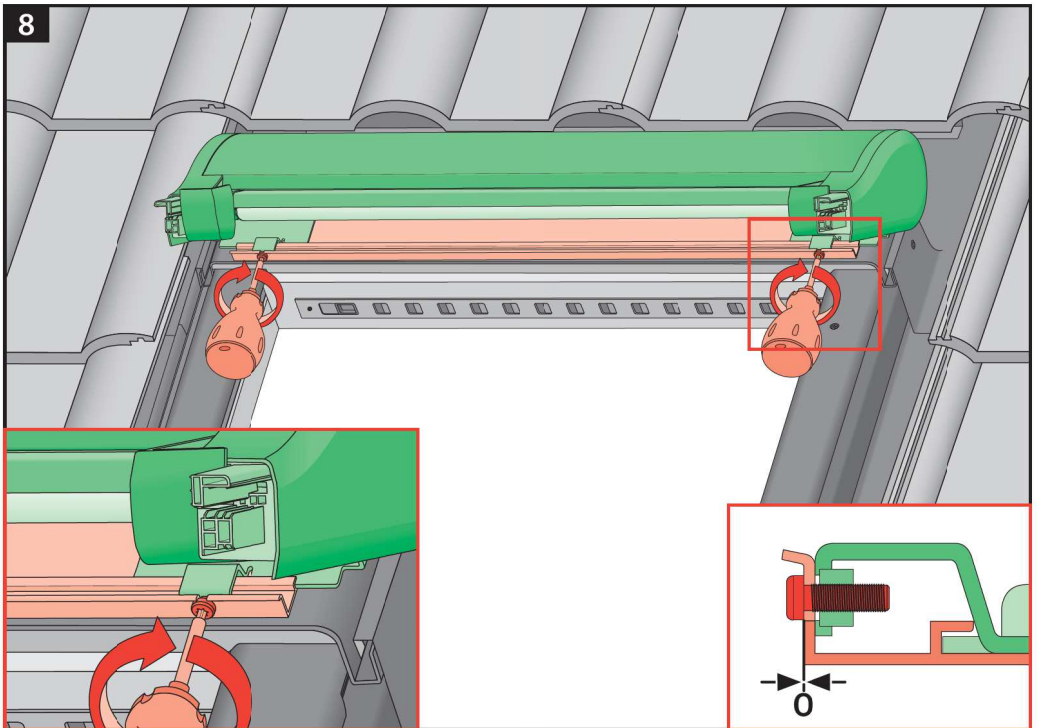
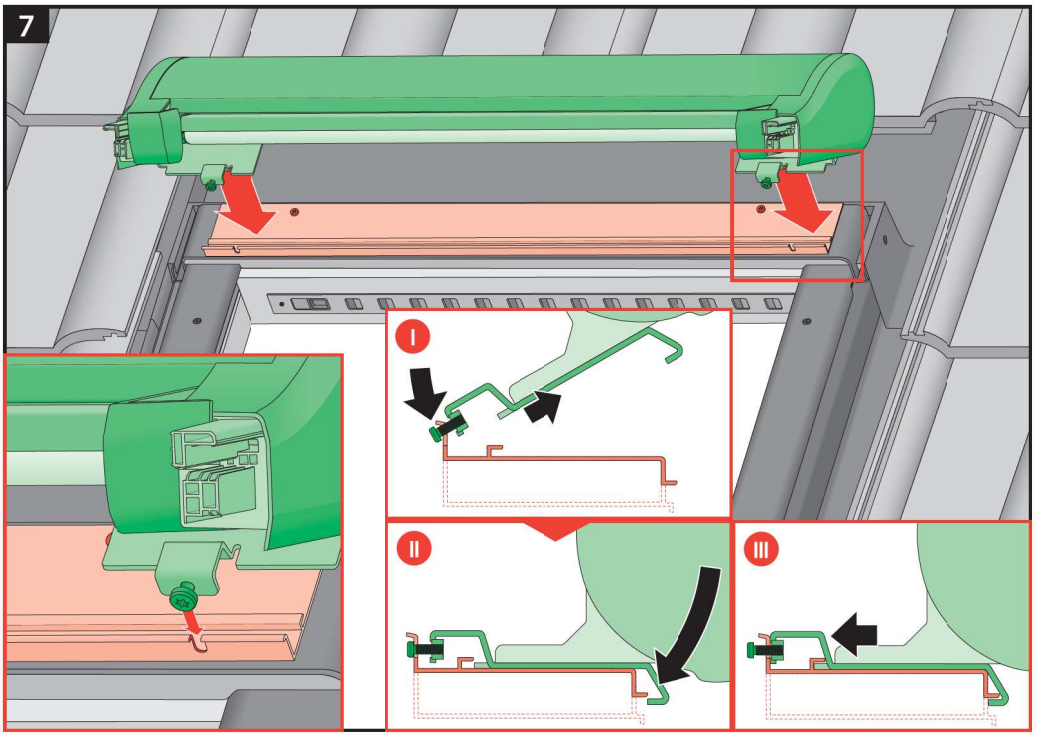

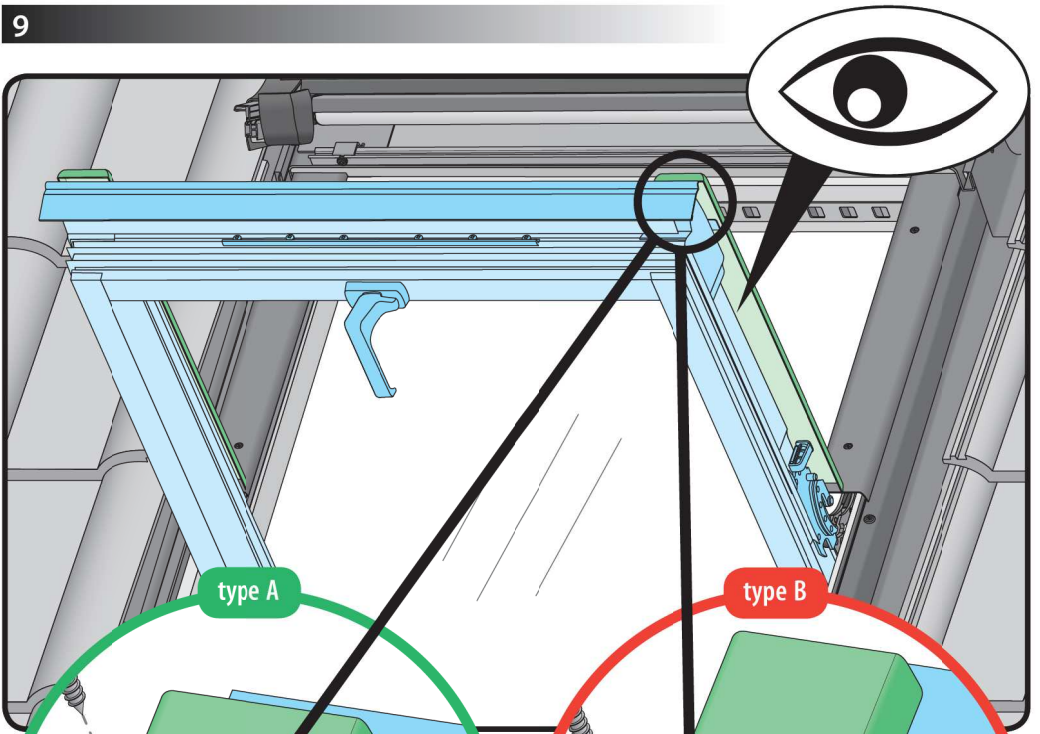

type A

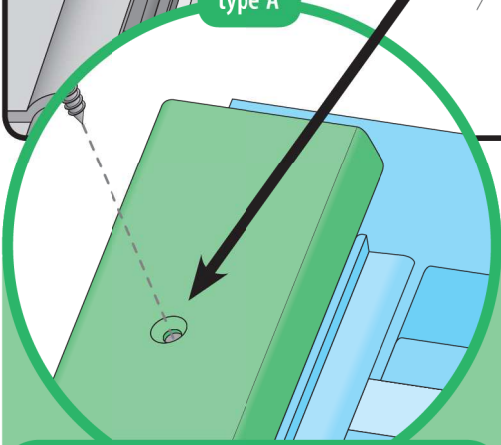

type B

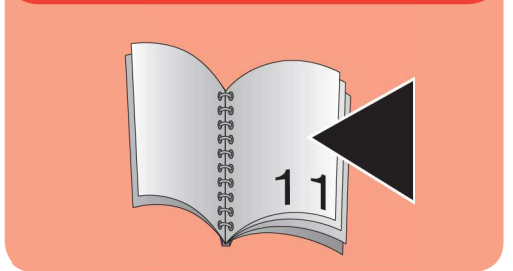
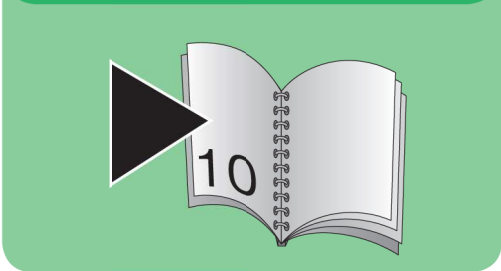
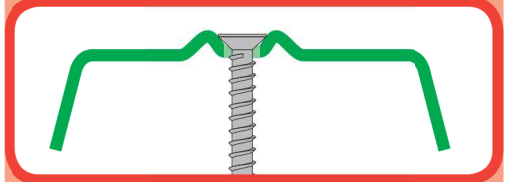
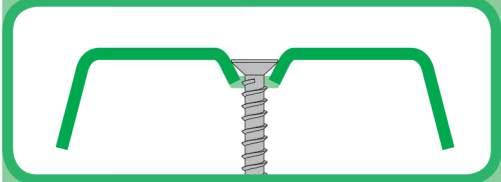
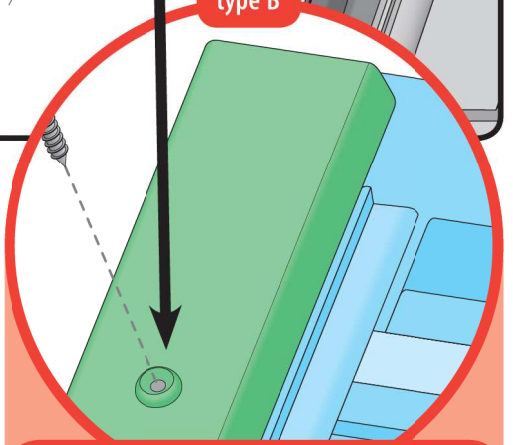

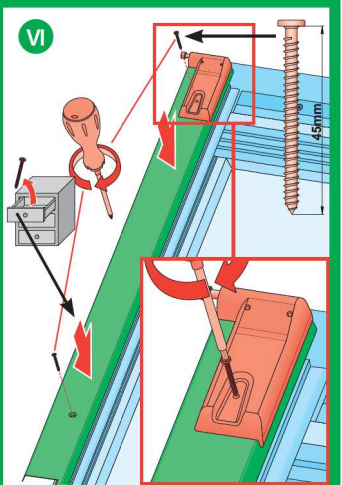
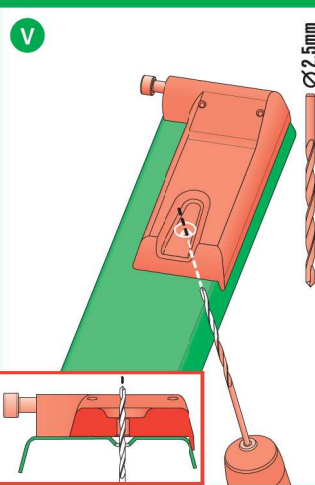
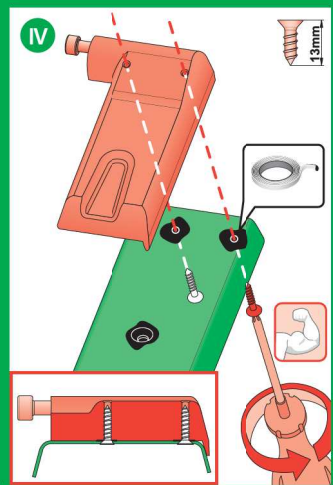
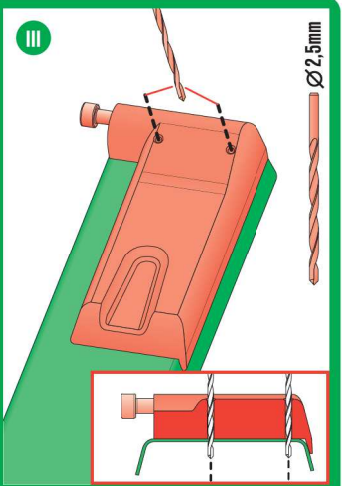
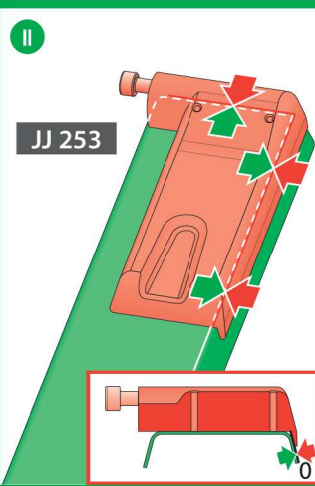
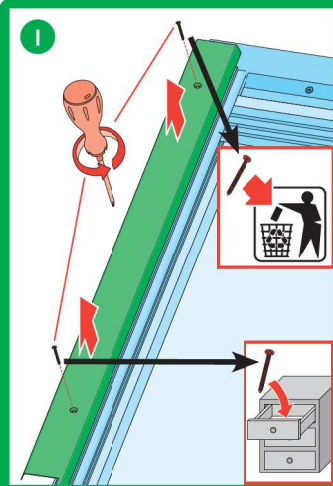
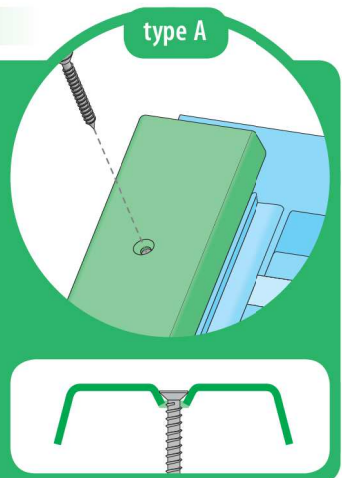
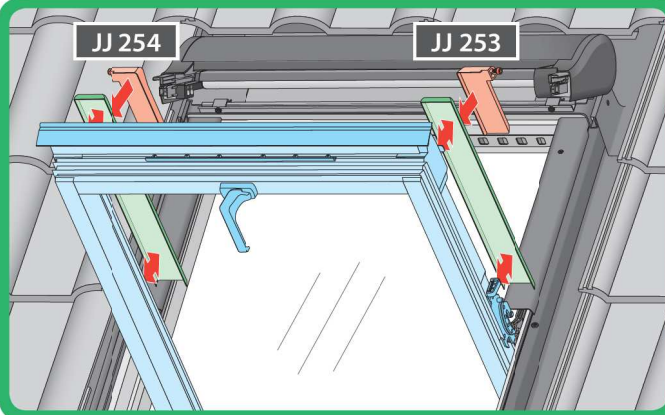

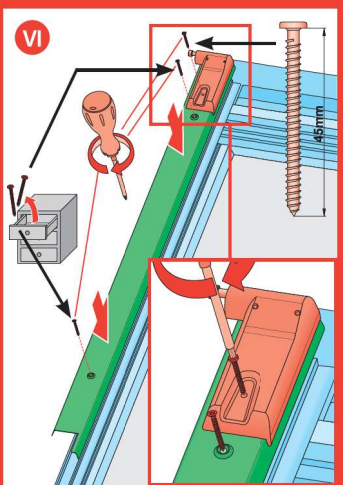
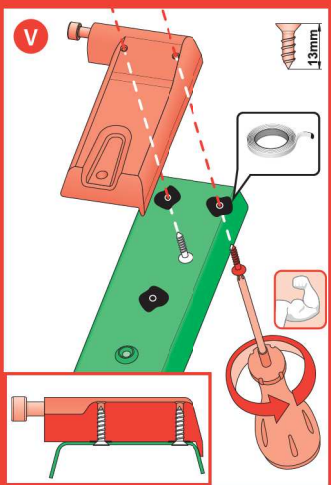
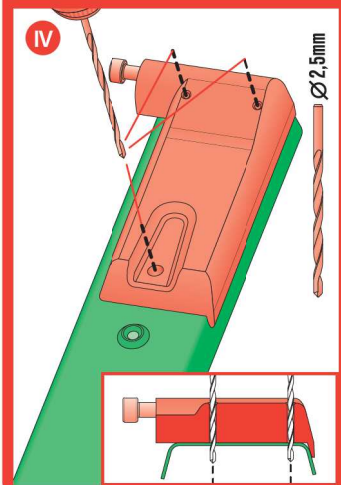
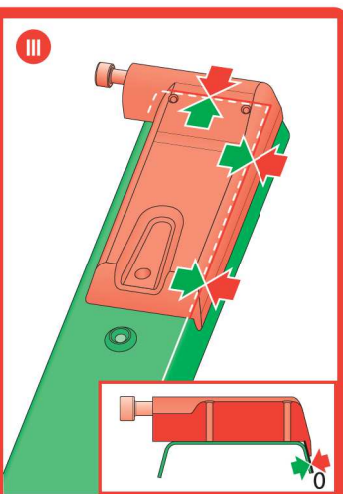
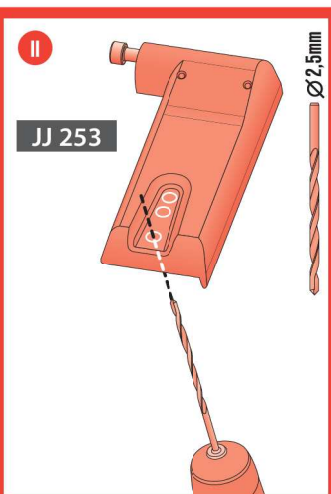
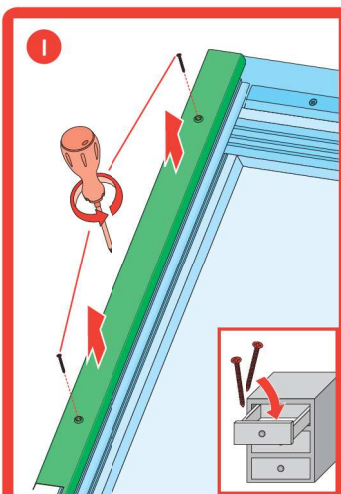
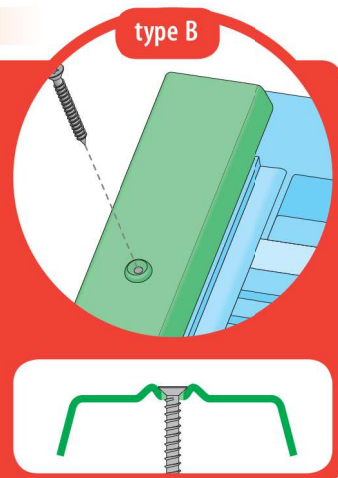
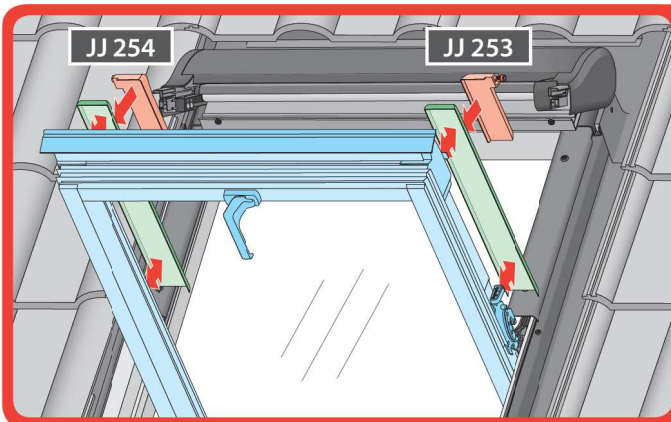

11a

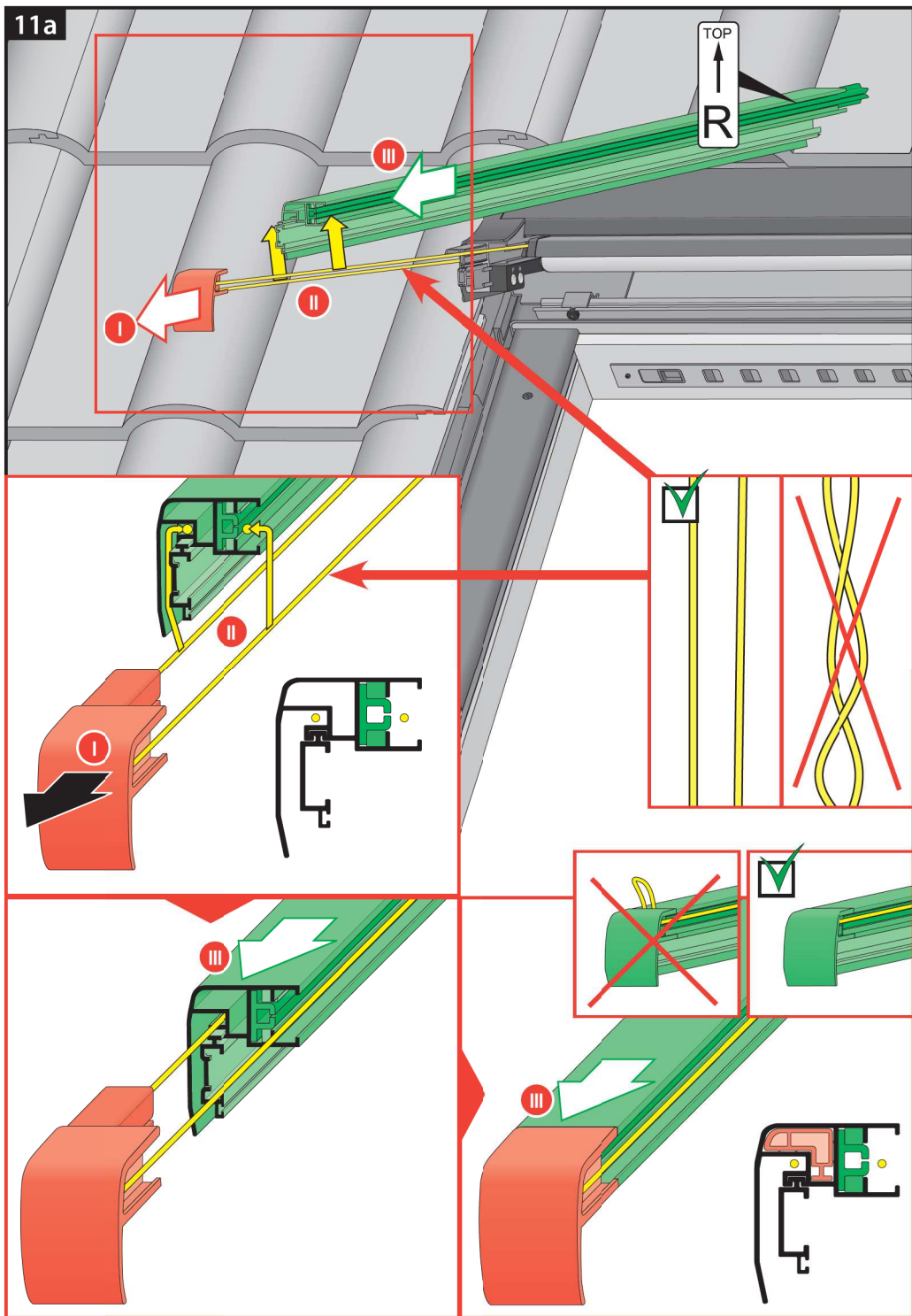

11b

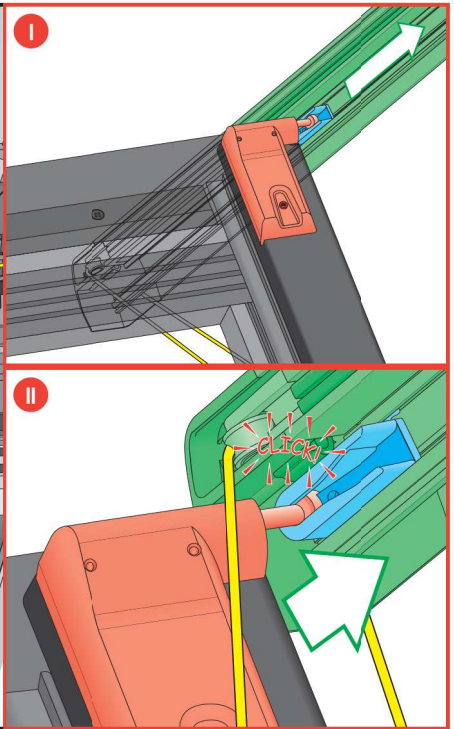
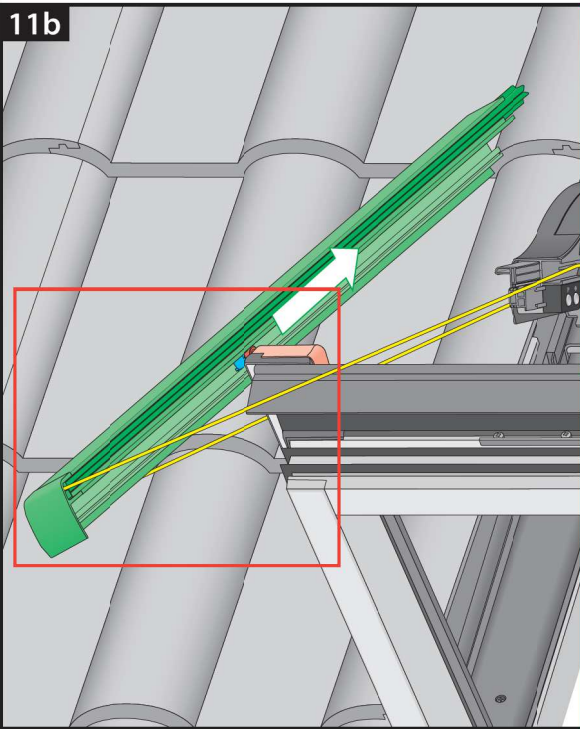

11c

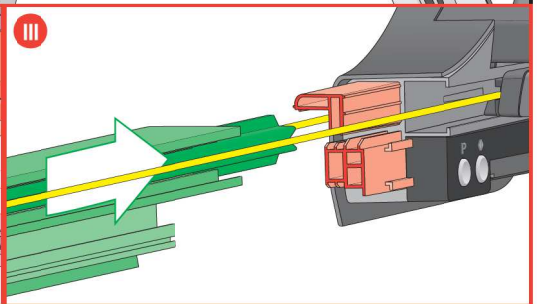
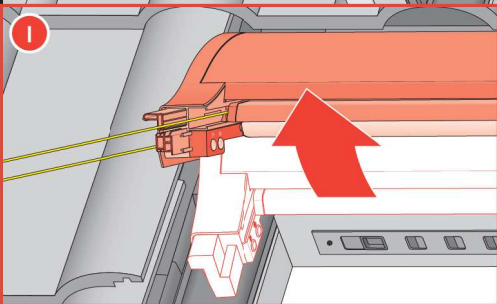
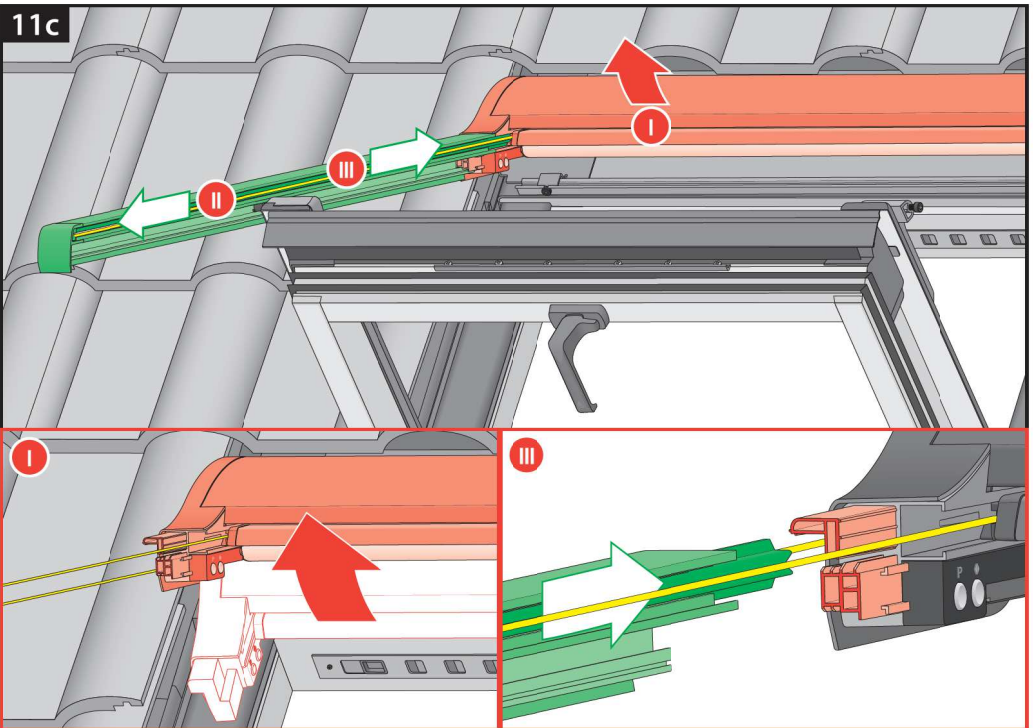

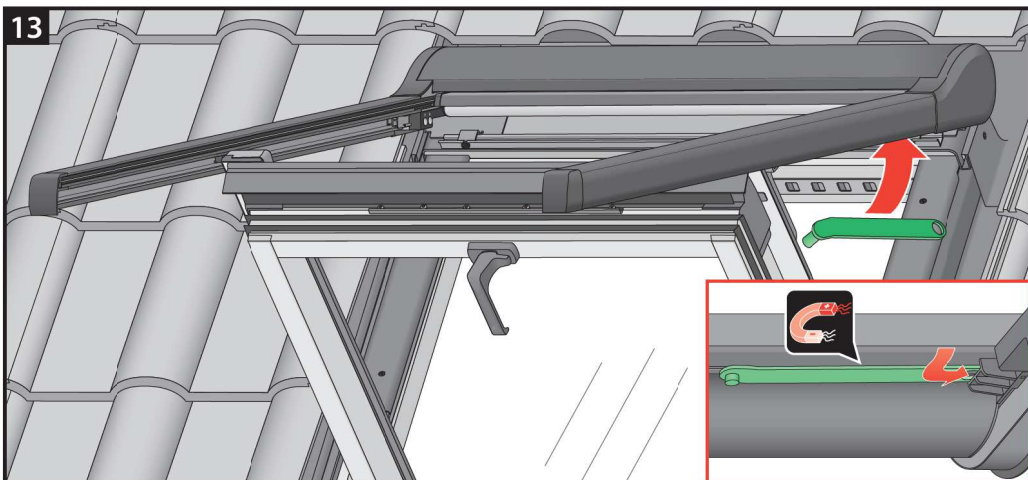
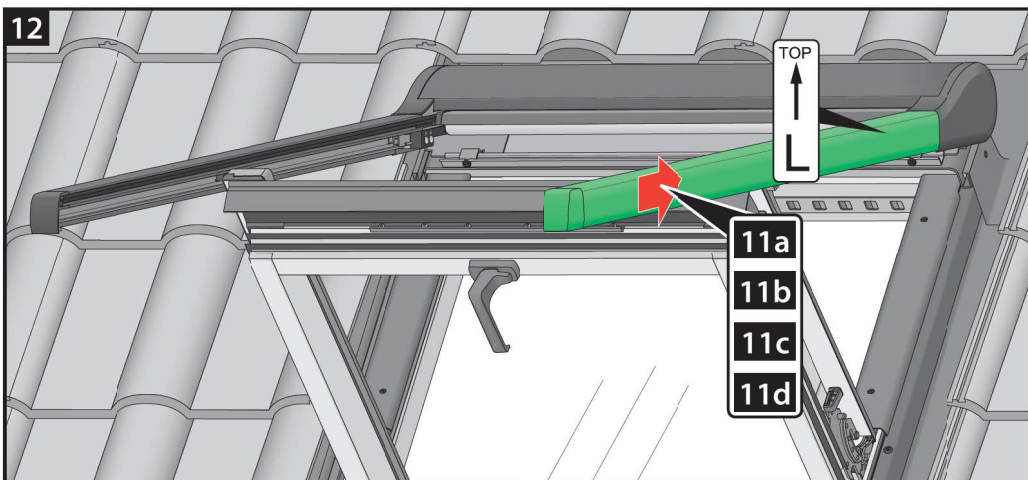
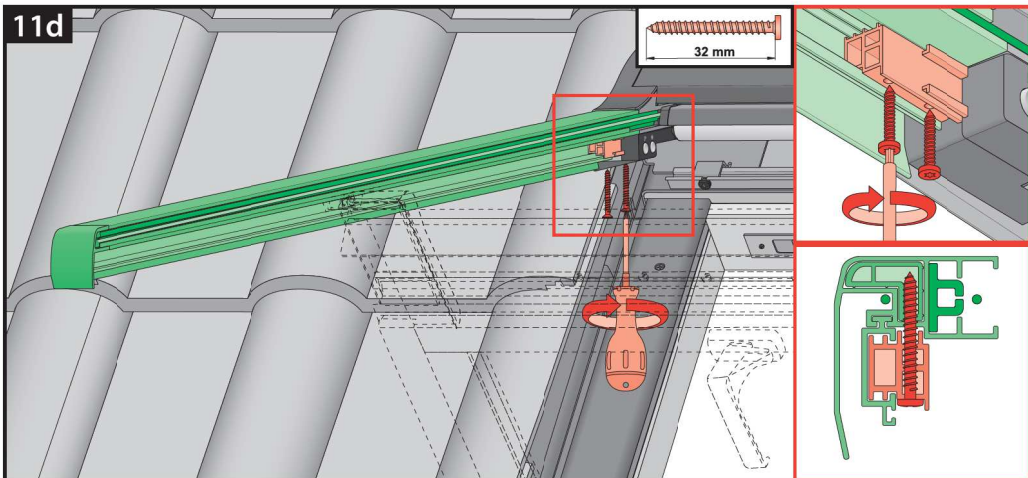

FTP-V Z-WAVE



14

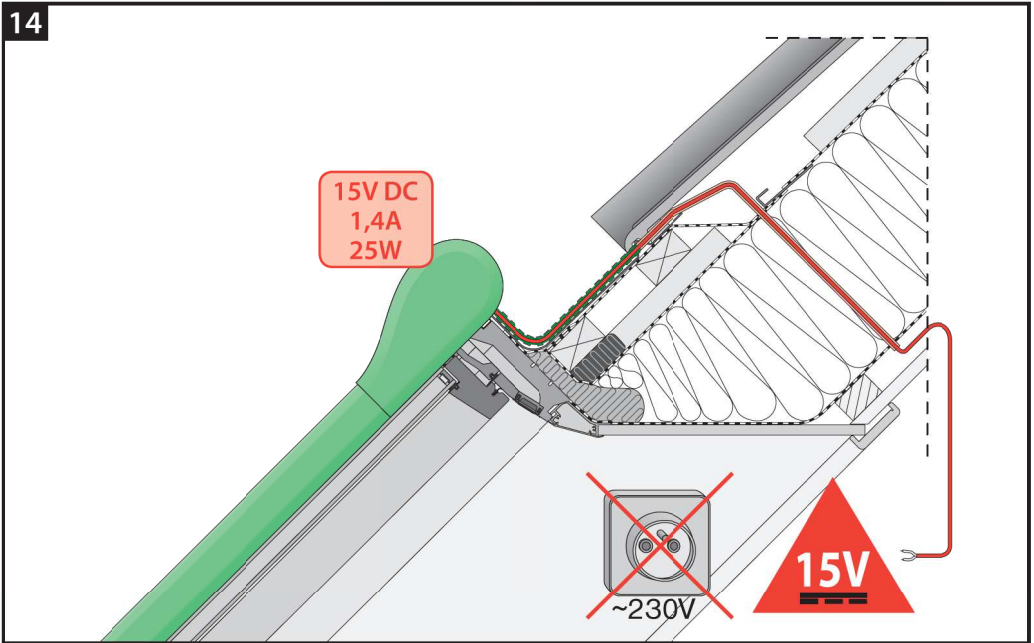

15

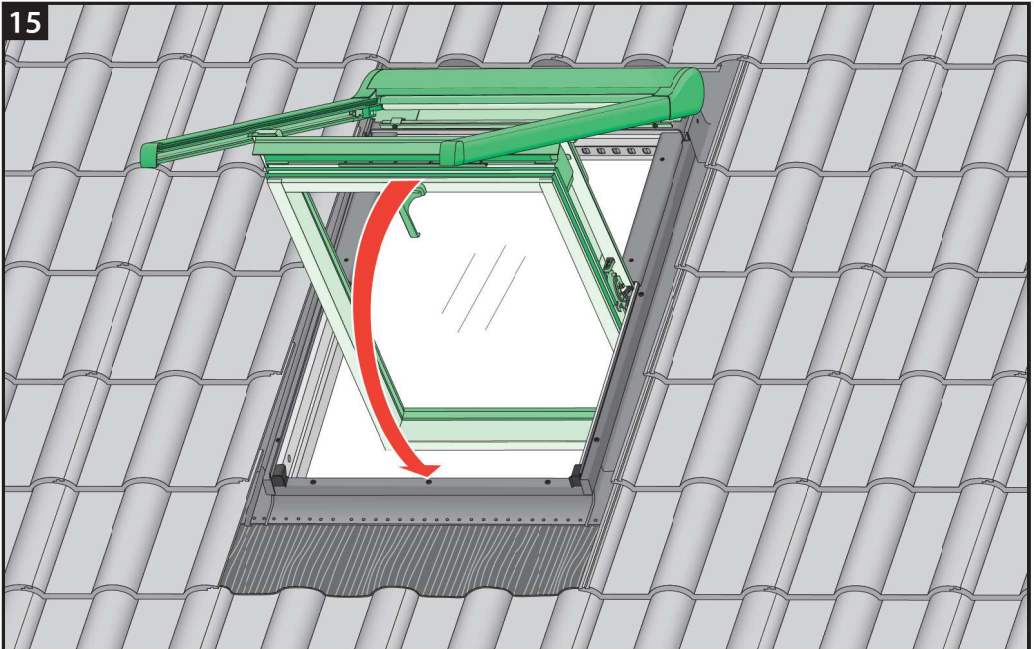

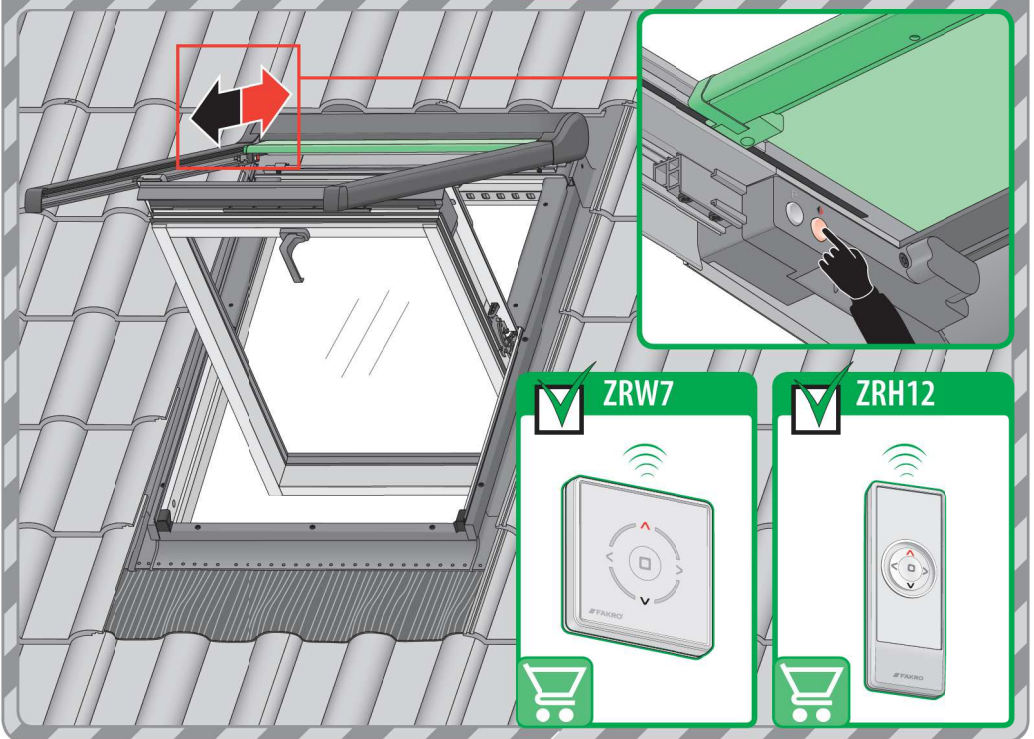
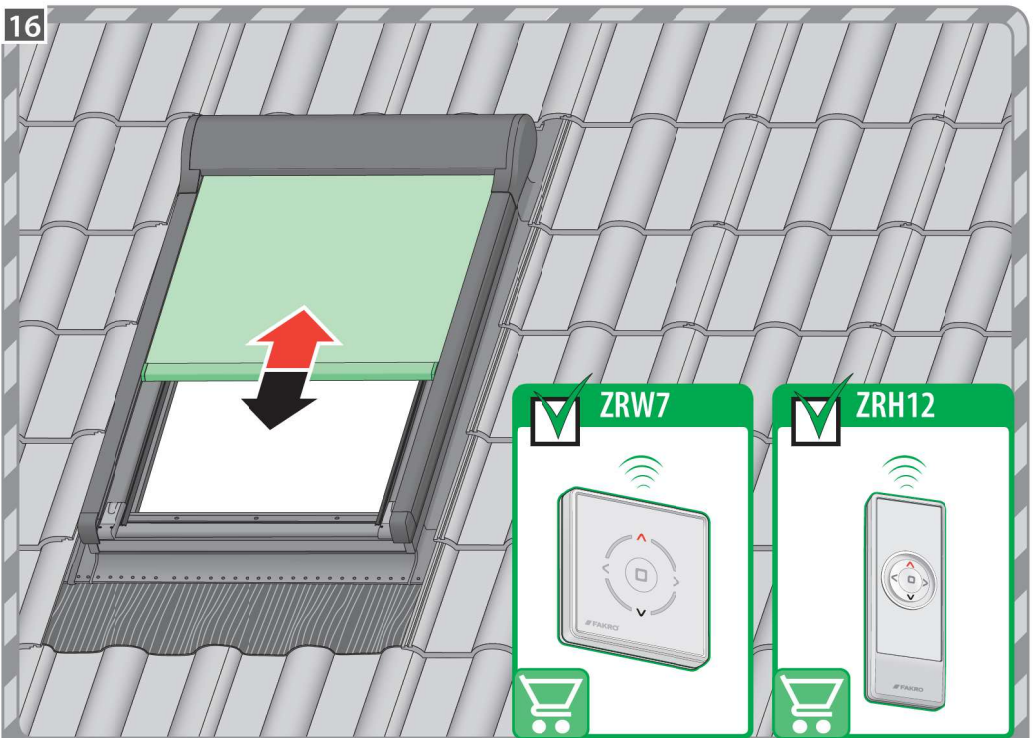

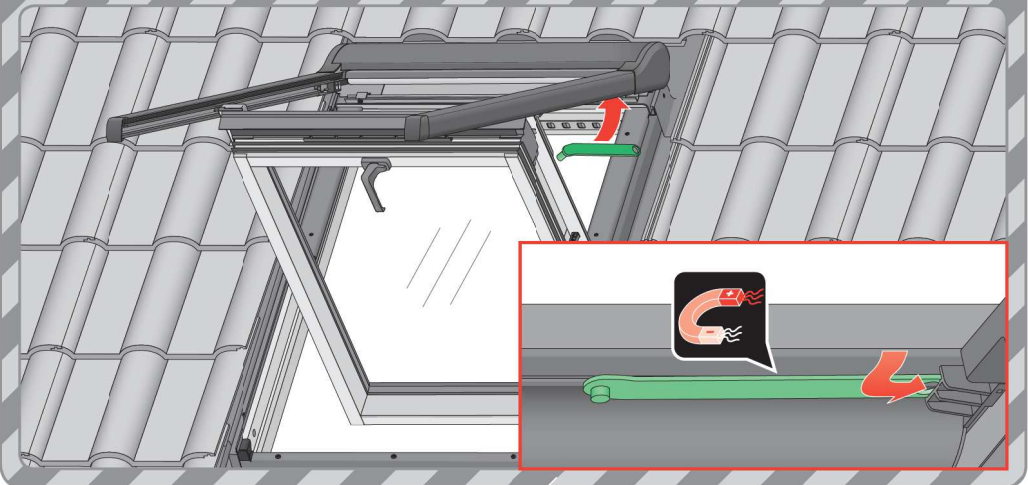
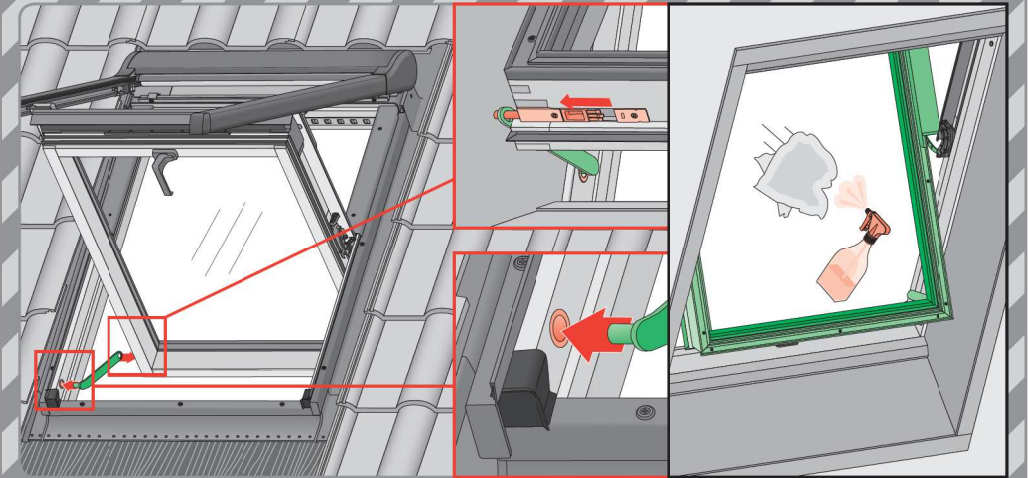
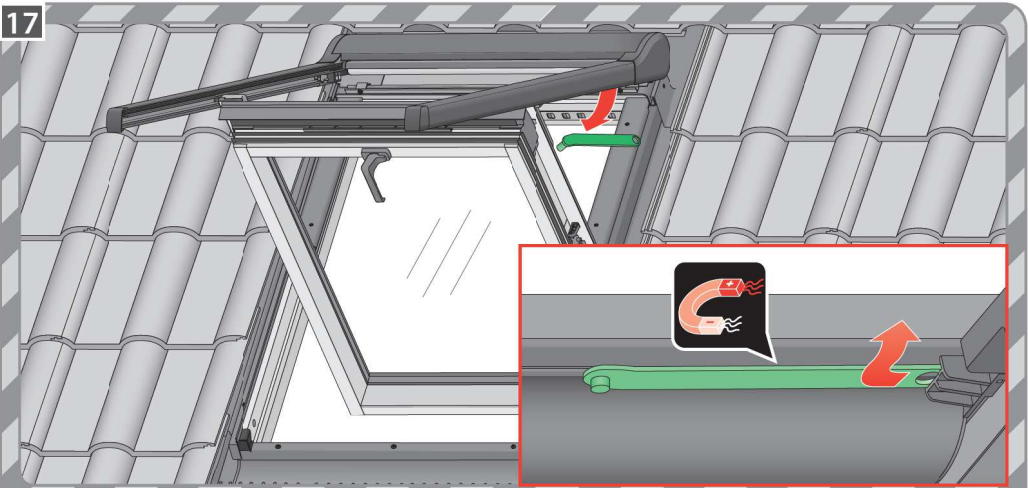

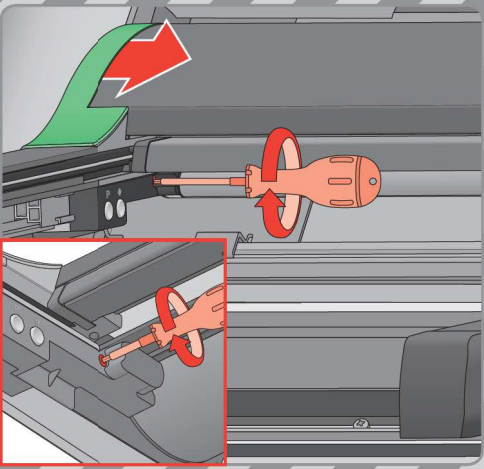
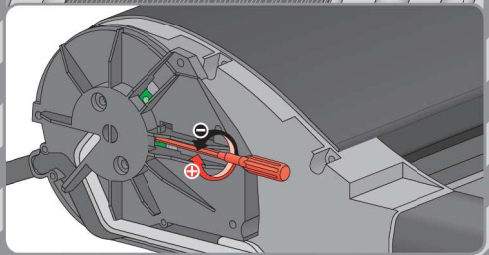
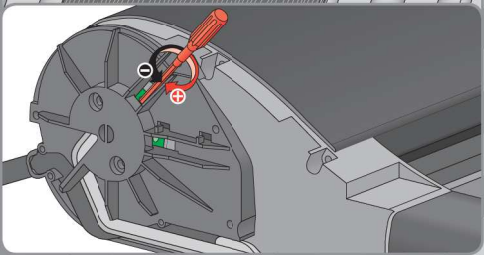
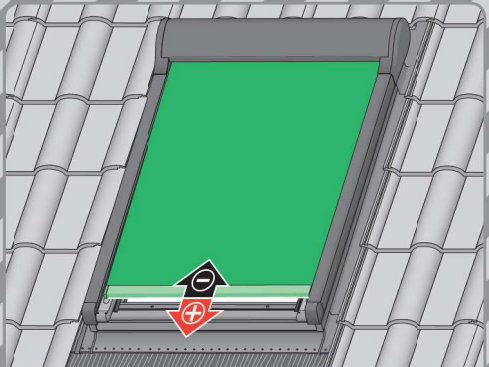
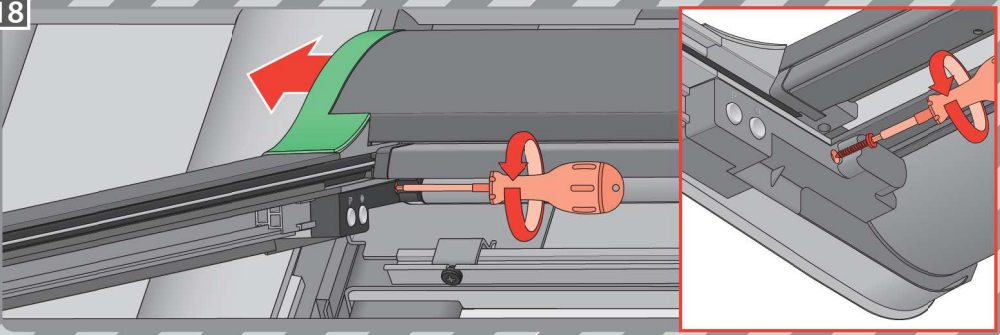

FTP-V Z-WAVE

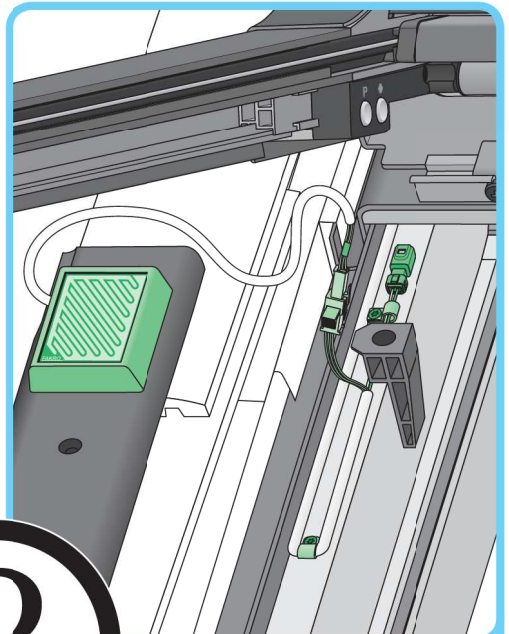
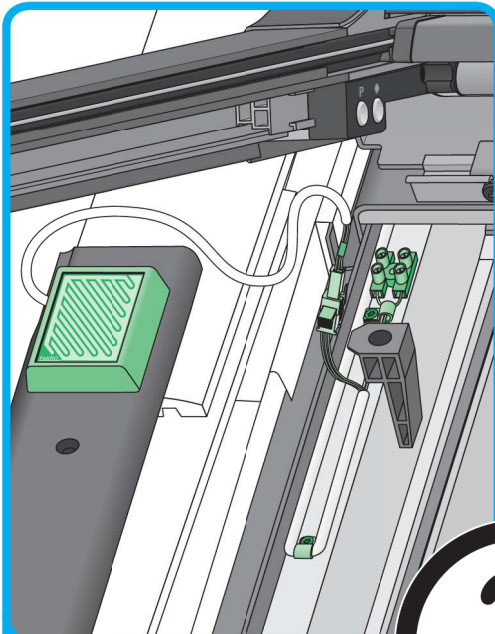
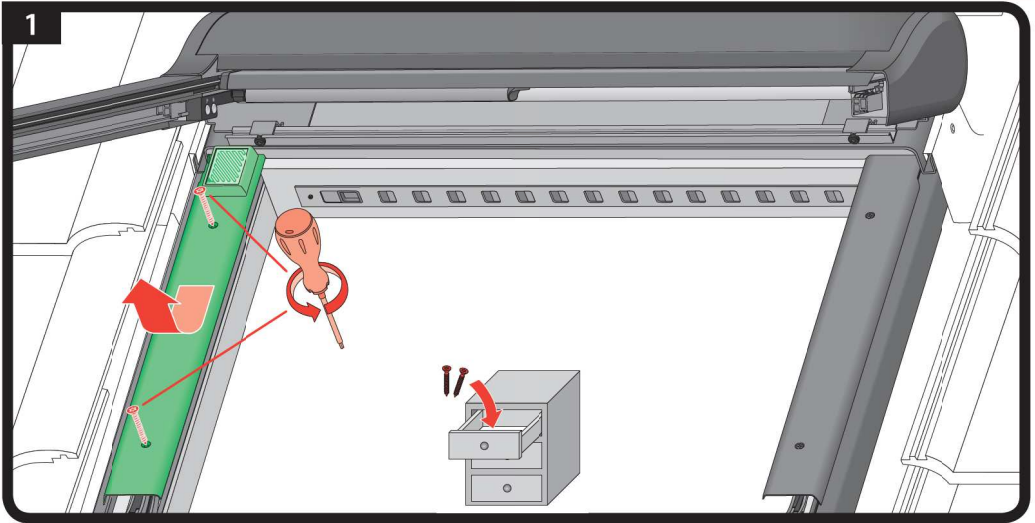

FTP-V Z-WAVE

2

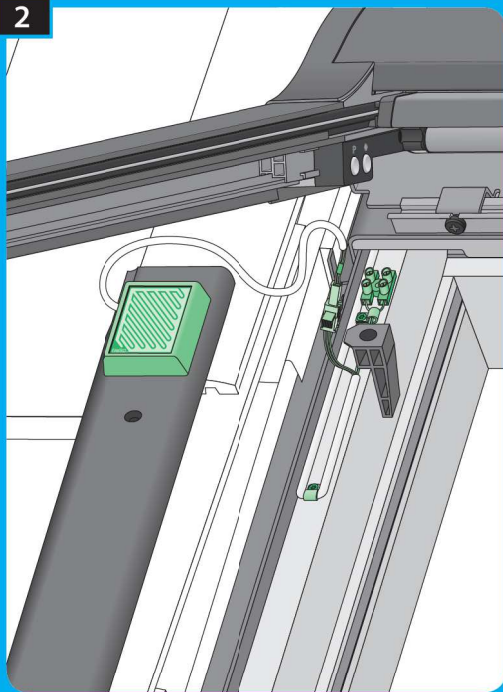

a

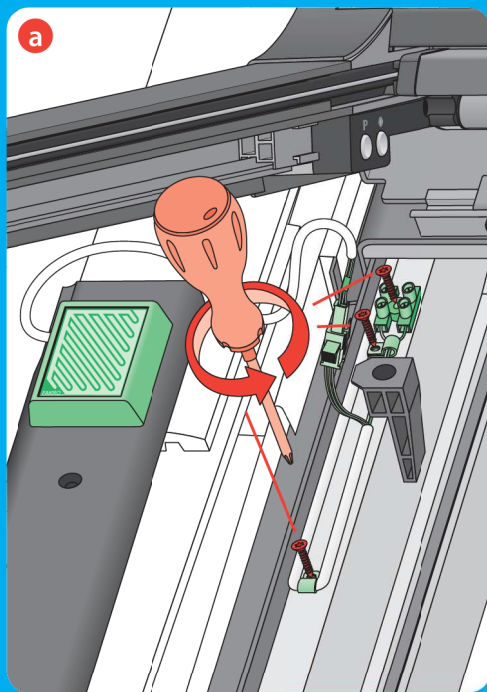

b

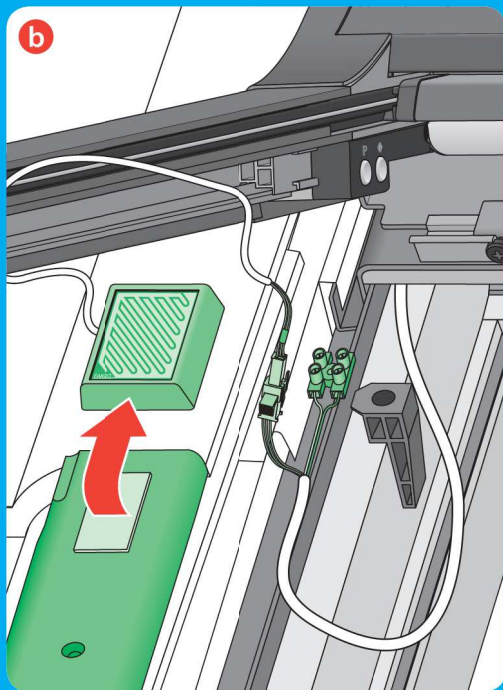

c

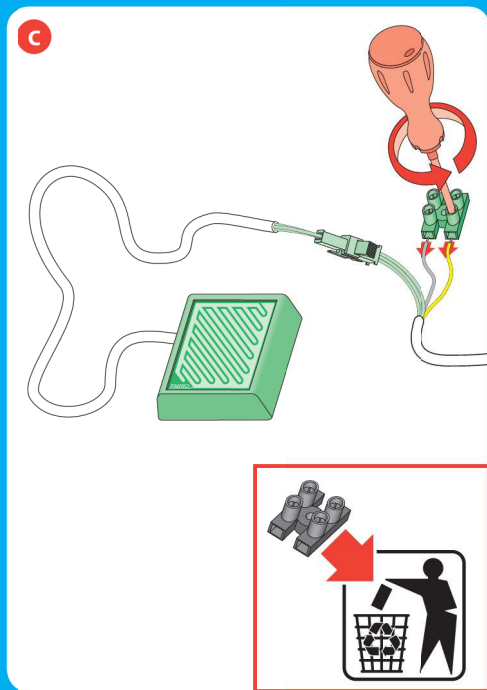

FTP-V Z-WAVE

3

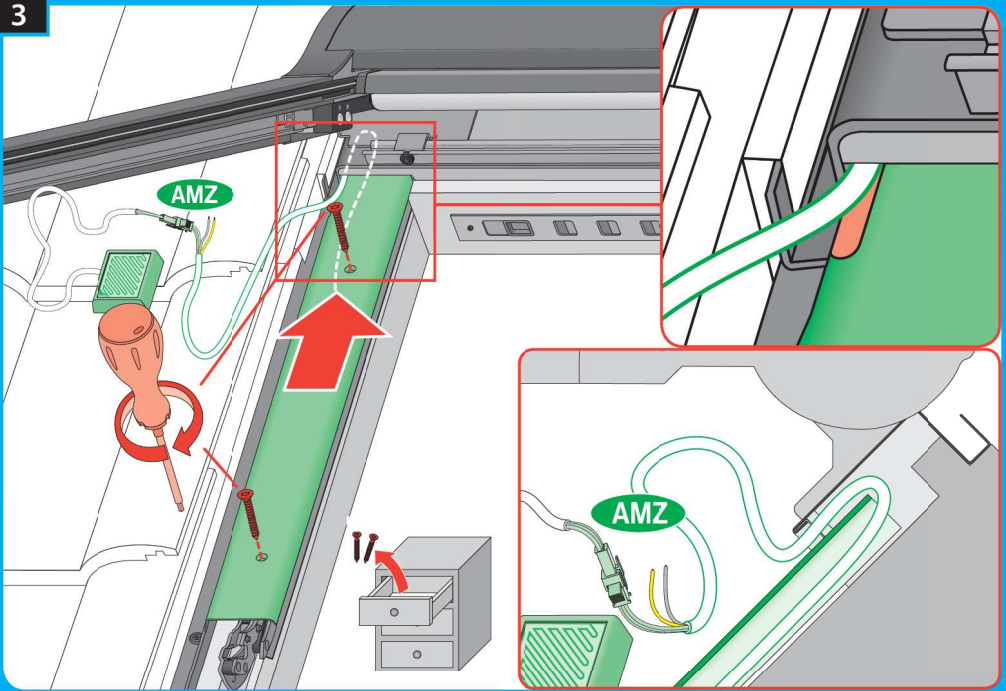

4

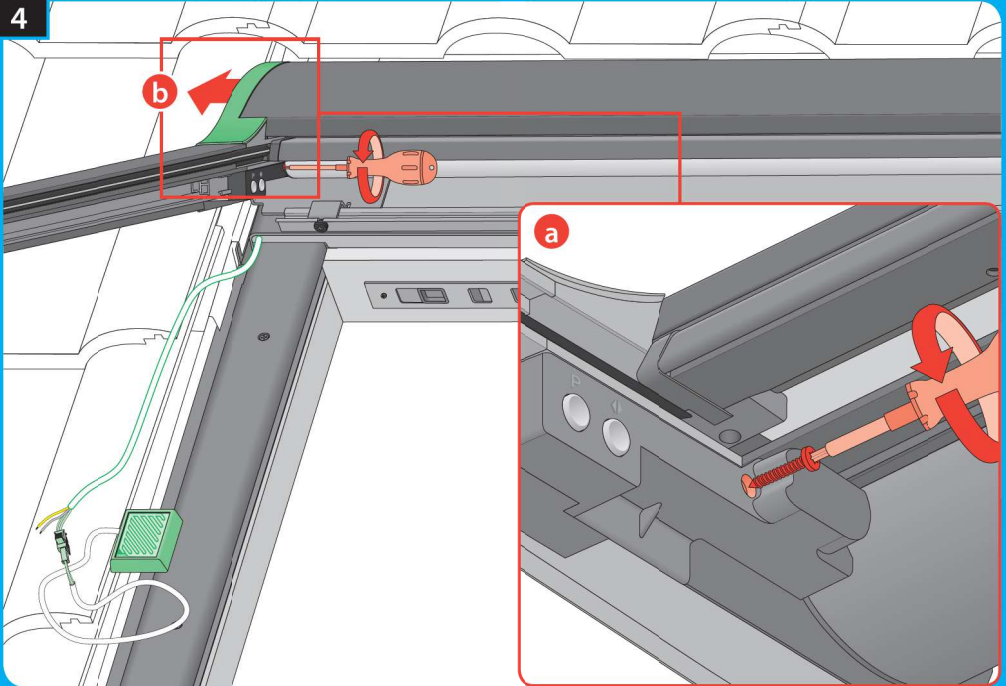

5

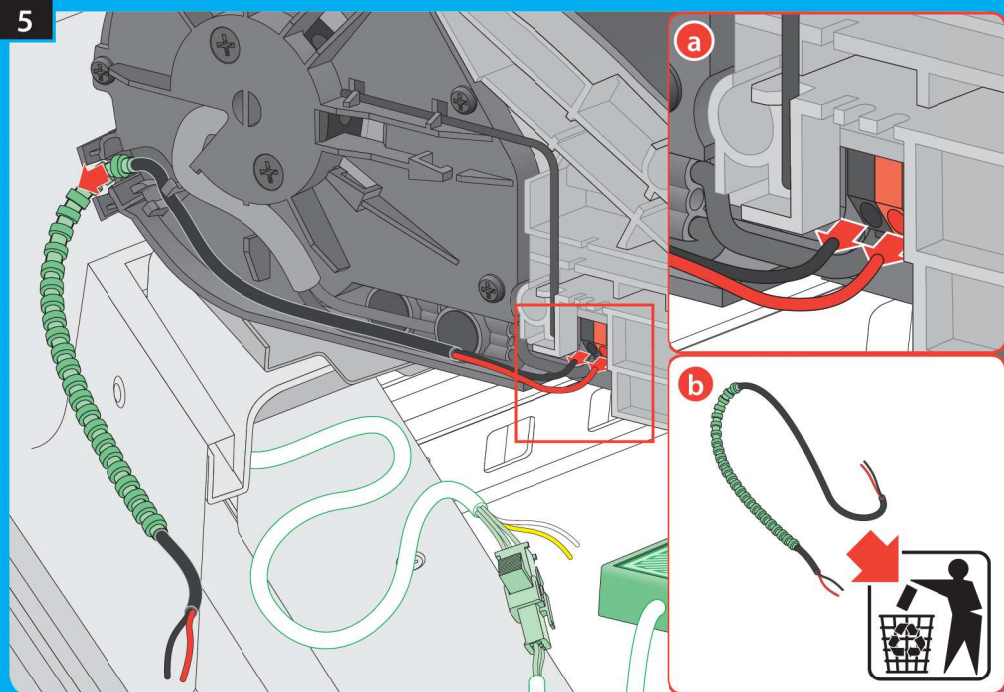

6

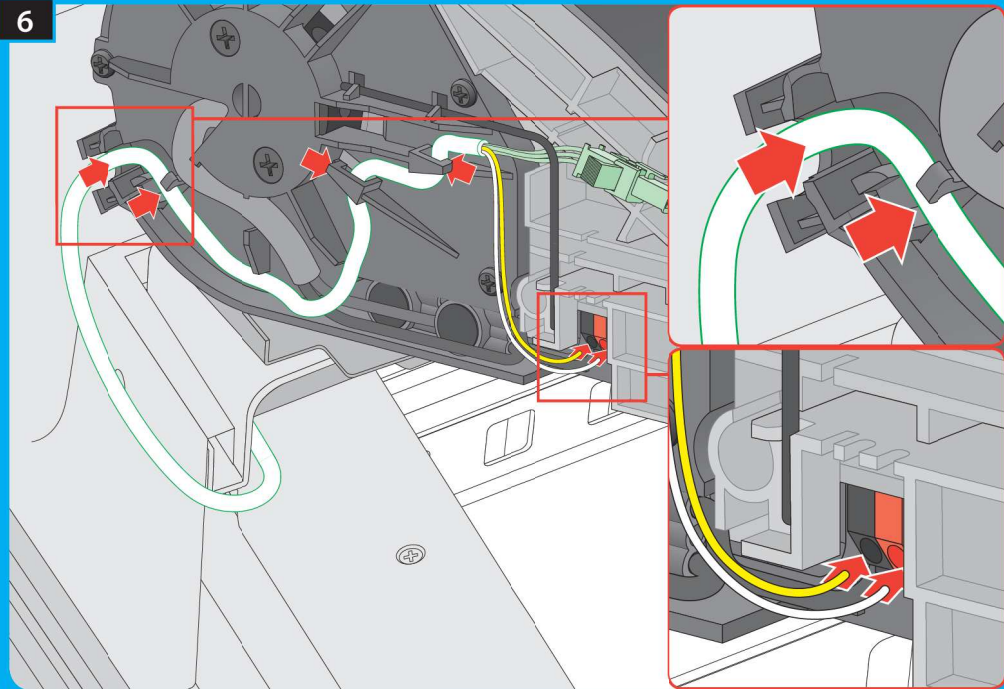

FTP-V Z-WAVE

7

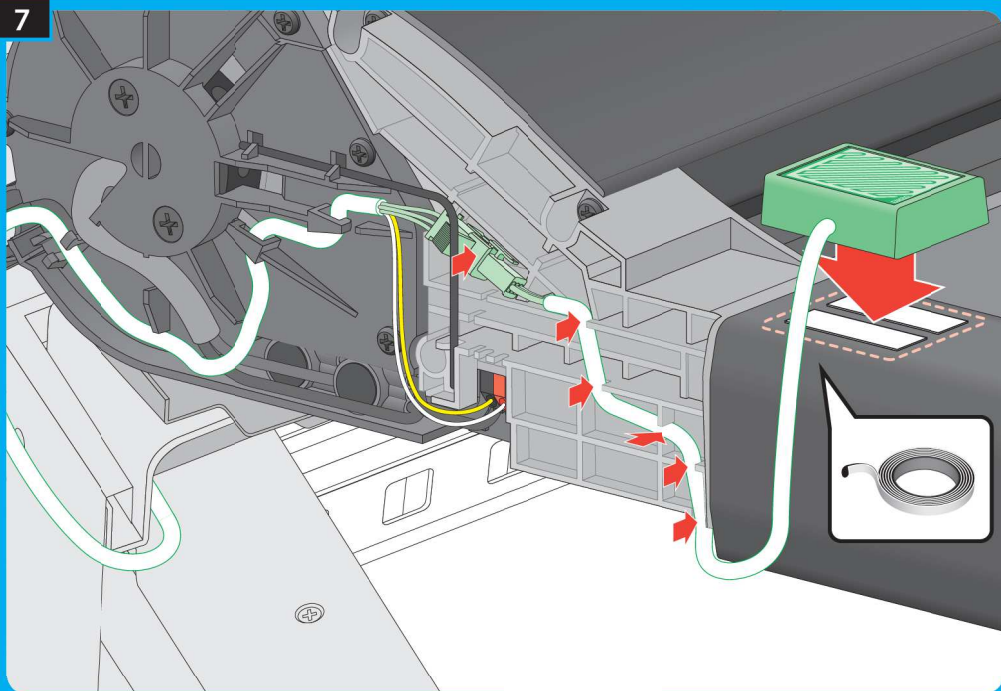

8

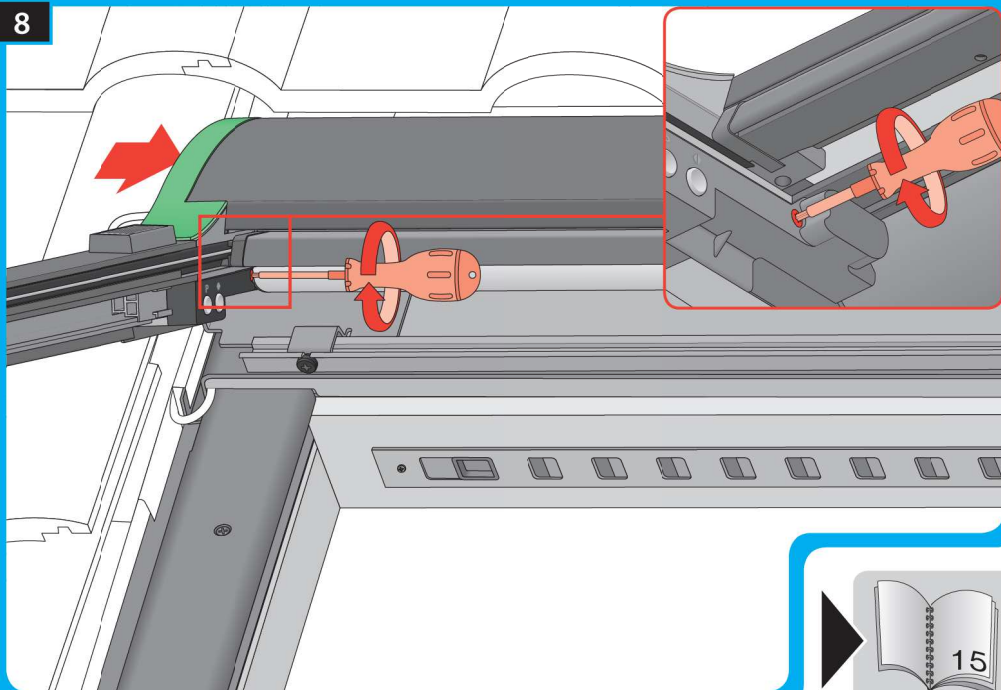

FTP-V Z-WAVE

2

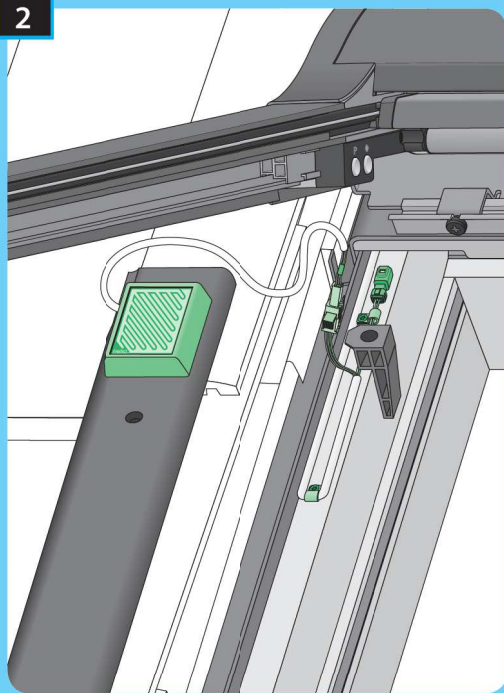

a

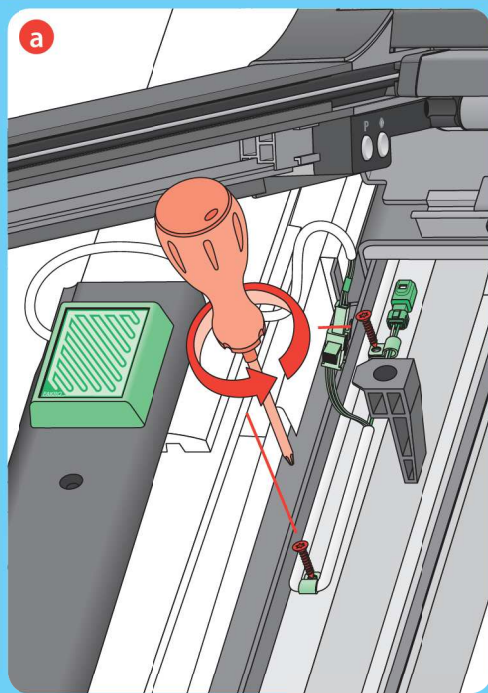

b

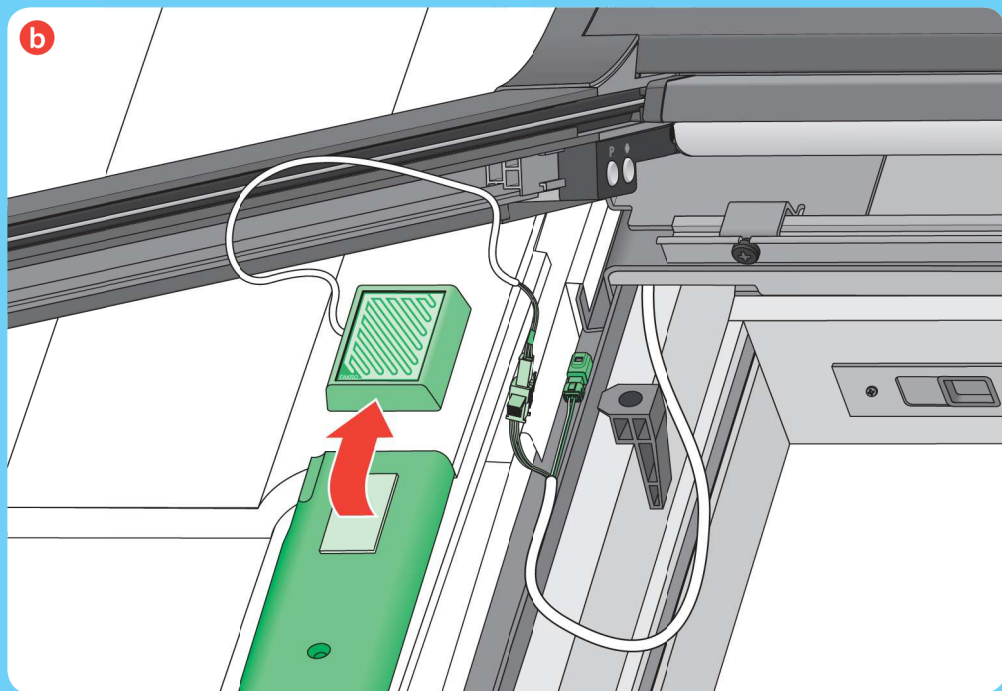

FTP-V Z-WAVE

3

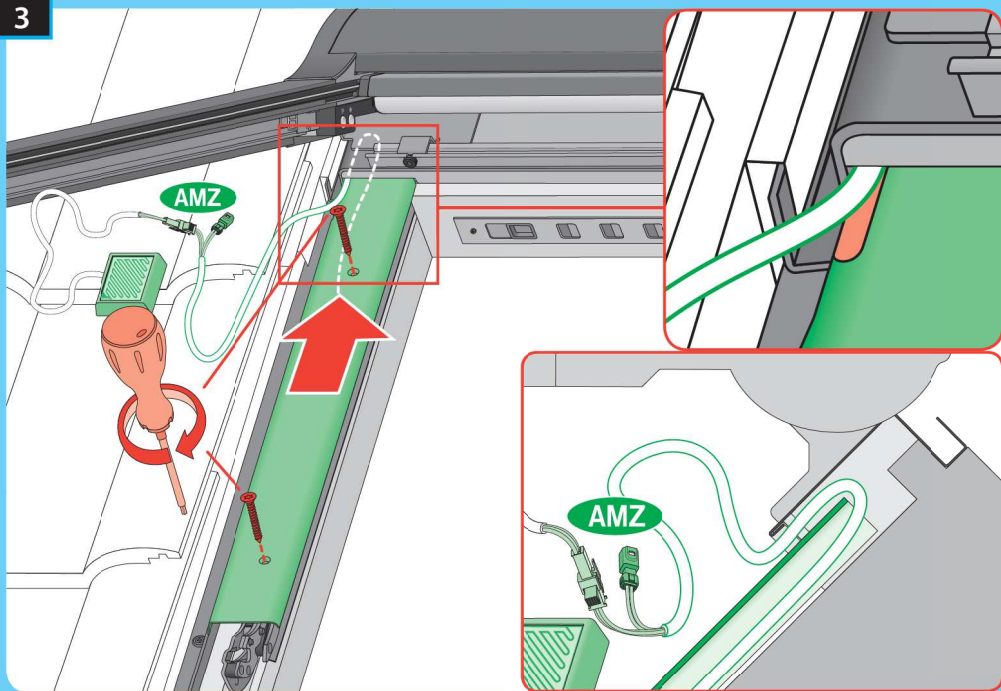

4

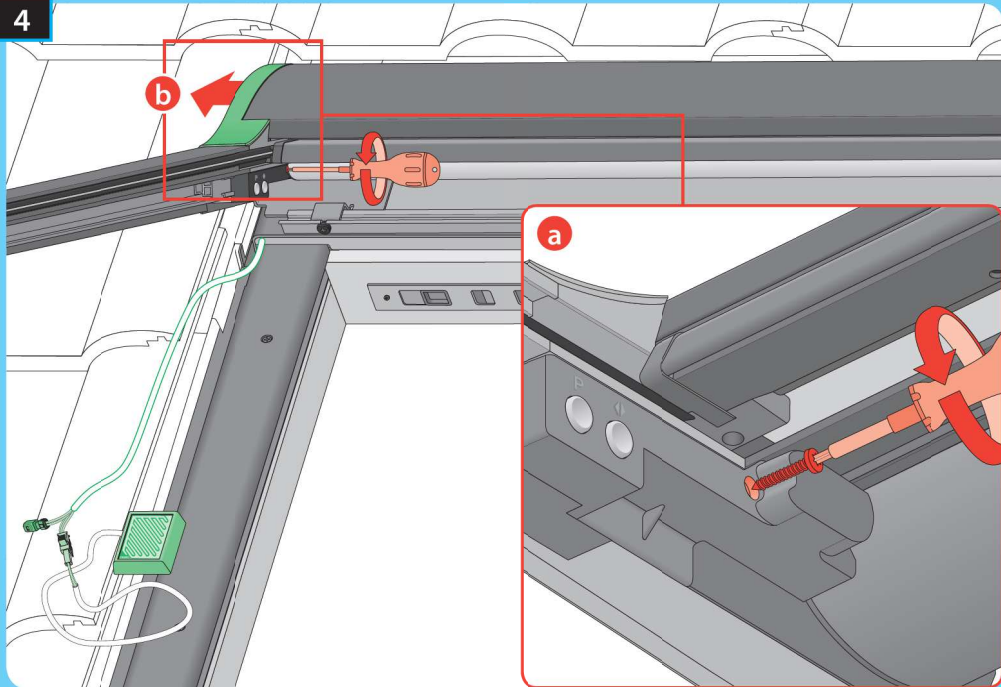

5

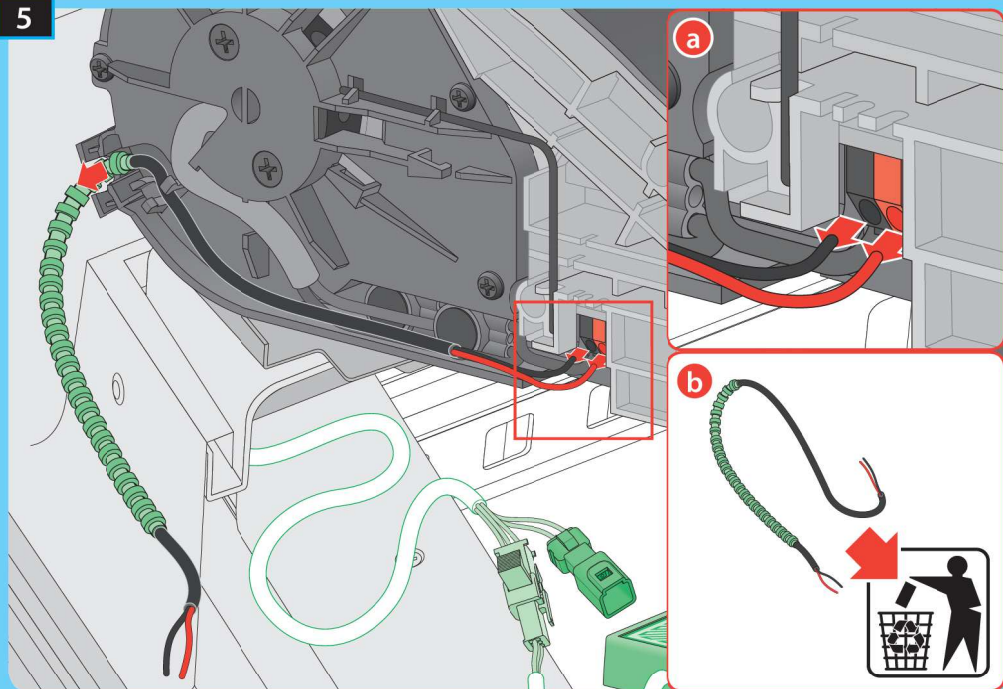

6

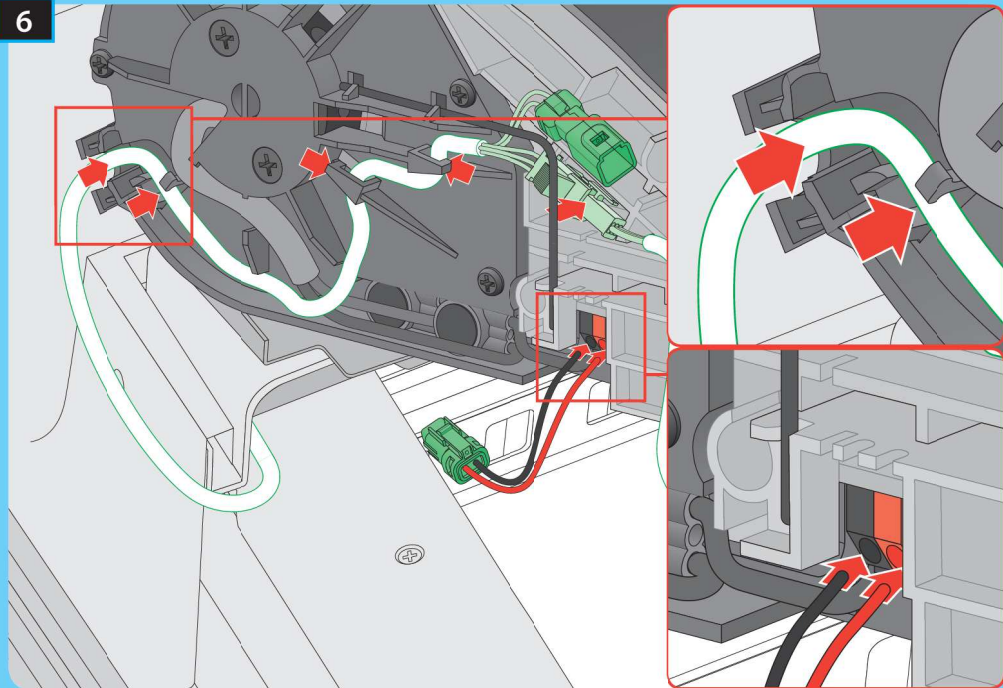

FTP-V Z-WAVE

7

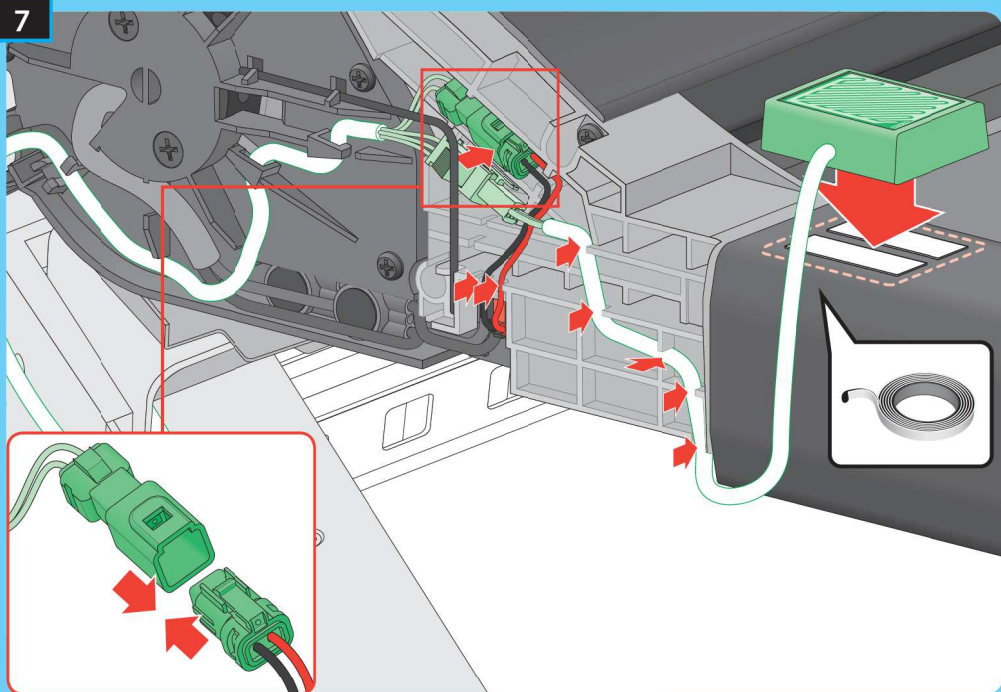

8

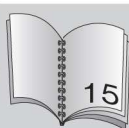
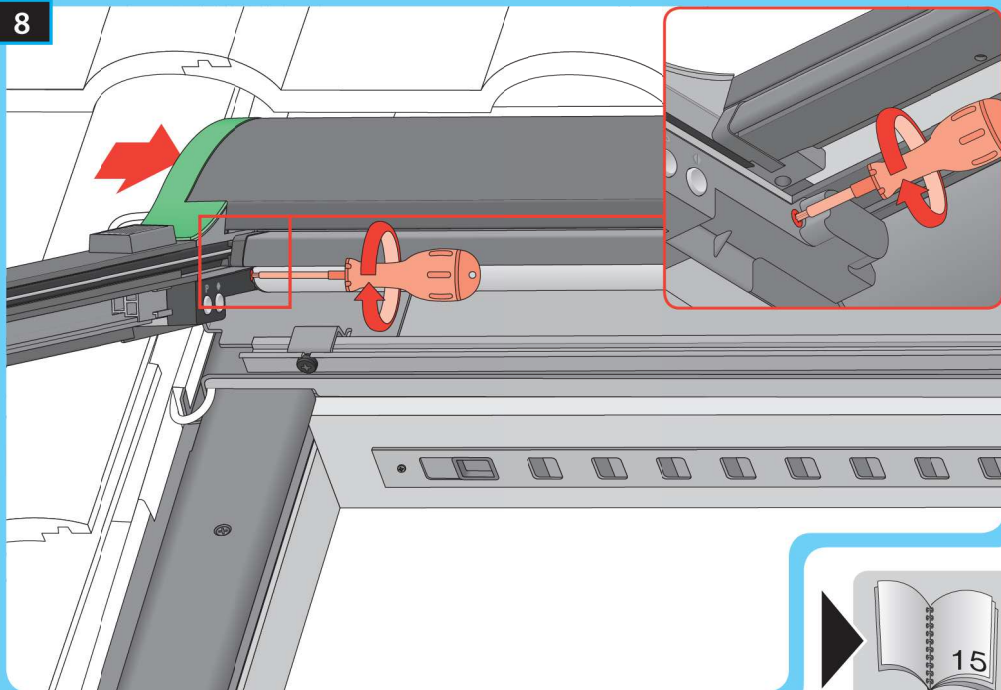

PL	Przed montażem należy zapoznać się z treścią instrukcji NC94Q „INSTRUKCJA ORYGINALNA 2/3 Zasady montażu i użytkowania”.
1	Wyjąć zaczep zabezpieczający znajdujący się pod kasetą.
2	Zablokować skrzydło za pomocą zaczepu.
3, 3a, 3b	Dobrać podstawę montażową w zależności od rodzaju kaptura okna a następnie przykręcić ją za pomocą wkrętów dołączonych do zestawu montażowego markizy.
4	Sprawdzić, czy okno wyposażone jest w otwór pod przewód zasilający dodatek.
5	Wykonać otwór w kapturze a następnie umieścić w nim gumowy przepust.
6	Wsunąć przewód zasilający w otwór.
7	Umieścić kasetę markizy na podstawie montażowej.
8	Przykręcić uchwyty markizy do podstawy montażowej.
9	Sprawdzić rodzaj przetłoczeń pod wkręty w profilach okna (type A lub type B).
10	Zamontować uchwyty dolne markizy do profili trapezowych okna.
11a	Wsunąć narożnik do prowadnicy markizy.
11b	Połączyć zaczep prowadnicy z uchwytem dolnym markizy.
11c	Wsunąć prowadnicę boczną w korpus markizy.
11d	Przykręcić prowadnicę do korpusu.
12	Powtórzyć czynności 11a- 11d dla prowadnicy lewej.
13	Umieścić zaczep zabezpieczający pod kasetą.
14	Podłączyć markizę do sieci za pomocą zasilacza 15VDC.
15	Zamknąć okno po zakończonym montażu.
16	Sterować markizą za pomocą przycisku na sterowniku lub pilota.
17	Do zabezpieczenia okna w pozycji „do mycia” używać zaczepu zabezpieczającego.
18	W razie potrzeby przeprowadzić regulację pozycji końcowych markizy.

EN	Before installation, it is compulsory to read the NC94Q „ORIGINAL INSTRUCTIONS 2/3 Installation and user manual”.
1	Remove the safety catch under the cassette.
2	Lock the sash with the catch.
3, 3a, 3b	Select the mounting base depending on the window hood type and then fix it using the screws included in the awning installation kit.
4	Check whether the window is equipped with an opening for the power cable for the accessory.
5	Make an opening in the hood and then place a rubber cable penetration.
6	Slide the power cable into the opening.
7	Place the awning cassette on the mounting base.
8	Screw the awning holders to the mounting base.
9	Check the corrugation type for screws in the window profiles (type A or type B).
10	Install the awning bottom holders to the trapezoidal profiles of the window.
11a	Slide the corner into the awning guide rail.
11b	Connect the guide rail catch with the awning bottom holder.
11c	Slide the side guide rail into the awning casing.
11d	Screw the guide rail to the casing.
12	Repeat steps 11a-11d for the left guide rail.
13	Place the safety catch under the cassette.
14	Connect the awning to the network using the 15VDC power supply.
15	Close the window after completed installation process.
16	Operate the awning using the button on the controller or remote control.
17	Use the safety catch to secure the window in the position for cleaning.
18	If required, adjust the end positions of the awning.



BG	Производител и Продавач не носят отговорност за неспазване на съответните закони, строителни норми и изисквания за безопасност от потребителя на продукта, архитекта, монтажника или собственика на сградата.
CZ	Uvinitel a prodejce nenesou žádnou odpovědnost za nedodržení příslušných právních zákonů, stavebních předpisů a bezpečnostních předpisů uživatelem výrobku, architektem, montážníkem nebo vlastníkem budovy.
DE	Hersteller und Verkäufer übernehmen keine Haftung für Nichtbeachtung entsprechender Rechts- und Bauvorschriften sowie Sicherheitsanforderungen seitens Produktbenutzers, Architekten, Monteurs oder Gebäudebesitzer.
ES	El fabricante y el vendedor no tienen ninguna responsabilidad por el incumplimiento de la ley vigente, normas de construcción y exigencias de seguridad por parte del usuario del producto, arquitecto, instalador o el propietario del edificio.
FR	Le fabricant et le vendeur ne prend aucune responsabilité de ne pas respecter les lois applicables, les règlements sur les bâtiments et les exigences de sécurité par l'utilisateur du produit, l'architecte, l'installateur ou le propriétaire du bâtiment.
GB	Manufacturer and Seller shall bear no liability for failure to comply with the applicable laws, building codes and safety requirements by the user of the product, architect, fitter or owner of the building.
HU	A gyártó és a forgalmazó nem vállal semmilyen felelősséget a vonatkozó törvények, építési és biztonsági előírások, termékhasználati, építési, beépítésmester vagy építésmunkások által be nem tartásáért.

IT	Il Produttore e il Rivenditore non potranno essere ritenuti responsabili per il mancato rispetto, da parte dell'utente del prodotto, del progettista, dell'installatore o del proprietario dell'edificio, delle leggi vigenti, nonché dei regolamenti edilizi e di quelli relativi alla sicurezza.
NL	De fabrikant en verkoper zijn niet aansprakelijk voor gevolgen bij het niet opvolgen van toepasselijke wetten, bouwvoorschriften en veiligheidsvoorschriften door de gebruiker van het product, de architect, de installateur of de eigenaar van het gebouw.
PL	Producent i Sprzedawca nie ponosi żadnej odpowiedzialności za nieprzestrzeganie stosownych przepisów prawa, przepisów budowlanych i wymogów bezpieczeństwa przez użytkownika produktu, architekta, montażystę lub właściciela budynku.
PT	Ofabricante e o vendedor não tem nenhuma responsabilidade pelo o não cumprimento da lei, códigos de construção e as exigências de segurança por parte do usuário do produto, arquiteto, instalador ou proprietário do edifício.
RO	Nici producătorul, nici distribuitorul nu își vor asuma niciun fel de răspundere pentru nerespectarea legilor în vigoare a legilor din domeniul construcțiilor sau a măsurilor de siguranță impuse utilizatorilor produsului, arhitecților, montajorilor sau proprietarilor clădirii.
RU	В случае несоблюдения архитектором, монтажником или владельцем здания строительных правил и норм безопасности ответственность с производителя и продавца снимается.
SK	Vnískva a predávca nenesú žiadnu zodpovednosť za nedodržanie príslušných ustanovení zákona, stavebných predpisov a bezpečnostných požiadaviek užívateľom výrobku, architektom, montérom alebo majiteľom objektu.